



Operation Manual

**LP 280**

**Nitrox Generator<sup>TM</sup>**

Rotair Version

If you have any questions on this equipment please contact Technical Support at:

Nuvair  
2949 West 5<sup>th</sup> St.  
Oxnard, CA 93030

Phone: 805-815-4044  
FAX: 805-815-4196  
Email: [info@nuvair.com](mailto:info@nuvair.com)

Hours: Monday through Friday  
8:00 AM to 5:00 PM PST USA



## WARNING

**This Operation Manual contains important safety information and should always be available to those personnel operating this equipment. Read, understand, and retain all instructions before operating this equipment to prevent injury or equipment damage.**

Every effort was made to ensure the accuracy of the information contained within. Nuvair, however, retains the right to modify its contents without notice. If you have problems or questions after reading the manual, stop and call for information.

# Table of Contents

## Introduction

1.0	Introduction .....	4
2.0	Safety Warnings System Components .....	5
3.0	Safety and Operation Precautions .....	6
4.0	Legal Precautions .....	7
5.0	Theory of Operation .....	8
6.0	Low Pressure Rotary Screw Compressor Technical Data .....	9
7.0	System Components .....	10
8.0	Nitrox System Specifications .....	11
9.0	Component Identification .....	12
10.0	System Drawing/Schematic .....	14
11.0	System Flow Chart .....	15

## Setup, Operation, and Maintenance

12.0	Preparing Existing HP Compressors .....	16
12.1	Purification System Air/Nitrox Quality .....	16
12.2	Replacement of Compressor Lubricant .....	16
12.3	Installation of Fill Oxygen Analyzer .....	17
13.0	Installing the Nitrox System .....	18
13.1	Precautions .....	18
13.2	Attaching Compressor Intake Hose .....	19
13.3	Attaching Nitrogen Discharge Hose (Optional) .....	19
13.4	Output Pressure Adjustments .....	20
13.5	Electrical Power Connection .....	20
13.6	Air/Nitrox Quality Testing .....	21
14.0	Pre-Operation Instructions .....	22
14.1	Compressor Oil Levels .....	22
14.2	Membrane System Regulator and Flow Valve .....	22
14.3	Oxygen Analyzer Calibration .....	23
14.4	Attaching Scuba Cylinder .....	24
15.0	Producing Nitrox .....	25
15.1	Flow to Membrane .....	25
15.2	Setting Proper Pressure .....	26
15.3	Final Adjustments Before Pumping Nitrox .....	26
15.4	Pumping Nitrox .....	27
15.5	Pumping Air .....	29
15.6	Shutting Down .....	29
16.0	Nitrox Operation Notes .....	30
16.1	Correlation of Input Pressure to Oxygen Content .....	30
16.2	Hot Fills .....	30
17.0	Maintenance .....	31
17.1	Daily Maintenance .....	31
17.2	Routine Maintenance .....	31
17.3	Compressor Lubricant .....	33
17.4	LP Filtration .....	34
17.5	Spare Parts List .....	35
17.6	Service Record Log .....	36

Appendix .....	37
Supply and Breathing Air Specifications .....	37
Filter Element Life Factors .....	37
Material Safety Data Sheets .....	38
Owner's Warranty Responsibilities .....	42
Warranty .....	43

## Separate Manuals Included:

Nuvair Pro O2™ Oxygen Analyzer Operation Manual .....	44
Rotair Rotary Screw Compressor Operation & Maintenance Instructions & Parts Manuals.....	67

## 1.0 Introduction

This manual will assist you in the proper set-up, operation and maintenance of the Nuvair LP 280 Nitrox Generator™. Be sure to read the entire manual.

Throughout this manual we will use certain words to call your attention to conditions, practices or techniques that may directly affect your safety. Pay particular attention to information introduced by the following signal words:



**Indicates an imminently hazardous situation, which if not avoided, will result in serious personal injury or death.**



**Indicates a potentially hazardous situation, which if not avoided, could result in serious personal injury or death.**



**Indicates a potentially hazardous situation, which if not avoided, may result in minor or moderate injury. It may also be used to alert against unsafe practices.**



**Notifies people of installation, operation or maintenance information which is important but not hazard-related.**

## 2.0 Safety Warnings

Nuvair has taken extreme care in providing you with the information you will need to operate this system. However, it is up to you to carefully read this manual and make the appropriate decisions about system safety.



### WARNING

**This equipment is used to provide breathing gas for the purpose of underwater life support. Read this manual in its entirety. Failure to heed the warnings and cautions contained in this document may result in severe injury or death.**



### WARNING

**The equipment you will be using to manufacture nitrox (oxygen rich air) will expose you to both low and high-pressure gas. Gas, even under moderate pressures, can cause extreme bodily harm. Never allow any gas stream to be directed at any part of your body.**



### WARNING

**Any pressurized hose can cause extreme harm if it comes loose or separates from its restraint (or termination) while under pressure and strikes any part of your body. Use appropriate care in making and handling all gas connections.**



### DANGER

**Pure nitrogen is a colorless, odorless, tasteless gas that will not support life. Breathing gas mixtures containing more than 84% nitrogen at surface pressures will lead to unconsciousness and may cause death.**



### WARNING

**The nitrogen discharge from the Membrane System must be vented to the exterior of any closed building, boat, or similar enclosed space. Breathing gas mixtures containing more than 84% nitrogen at surface pressure will lead to unconsciousness and may cause death.**



### WARNING

**Do not use any form of mineral oil or synthetic lubricant not rated for nitrox in any compressor in this system. Use only the recommended Nitrox Compressor Lubricant. Never mix the Nitrox Compressor Lubricant with other lubricants. Remove all existing lubricant and replace with the proper Nitrox Compressor Lubricant prior to installing the Membrane System. The use of improper lubricants can lead to fire or explosions, which may cause serious personal injury or death.**



## WARNING

**Do not use this system to produce nitrox mixtures containing more than 40% oxygen. Pumping nitrox mixtures with higher concentrations of oxygen may lead to fires or explosions, which can cause serious personal injury or death.**



## WARNING

**The use of enriched air nitrox does not eliminate the risk of decompression sickness (DCS) in diving. Decompression sickness can lead to permanent disability or death.**



## WARNING

**Do not pump nitrox mixtures at pressures above the compressor manufacturer's rating, and never above 3600 P.S.I. (250 bar). The system is not rated for pressures above 3600 P.S.I. (250 bar). Higher pressures may lead to explosions which may cause serious personal injury or death.**



## WARNING

**Some compressors are not suitable for compressing oxygen-rich air, i.e., nitrox. Use of an unsuitable compressor may lead to possible compressor damage and/or fires or explosion. This can lead to serious personal injury or death. If there is any doubt regarding the use of an existing compressor, contact Nuair or the compressor manufacturer before you connect your Membrane System to your machinery.**



## CAUTION

**Ambient room temperature should never exceed 100°F (38°C) during operation of the Nitrox System. Operation at higher temperatures may lead to system damage and malfunction. A damaged membrane will not produce the correct nitrox mixture which can lead to severe personal injury if the gas is used for diving purposes without proper analysis.**

### 3.0 Safety And Operation Precautions

Because a Compressor is a piece of machinery with moving and rotating parts, the same precautions should be observed as with any piece of machinery of this type where carelessness in operations or maintenance is hazardous to personnel. In addition to the many obvious safety precautions, those listed below must also be observed:

- 1) Read all instructions completely before operating any compressor or Nitrox System.
- 2) For installation, follow all local electrical and safety codes, as well as the National Electrical Code (NEC) and the Occupational Safety and Health Administration (OSHA) standards.
- 3) Electric motors must be securely and adequately grounded. This can be accomplished by wiring with a grounded, metal-clad raceway system to the compressor starter; by using a separate ground wire connected to the bare metal of the motor frame; or other suitable means.
- 4) Protect all power cables from coming in contact with sharp objects. Do not kink power cables and never allow the cables to come in contact with oil, grease, hot surfaces, or chemicals.

- 5) Make certain that power source conforms to the requirements of your equipment.
- 6) Pull main electrical disconnect switch and disconnect any separate control lines, if used, before attempting to work or perform maintenance. "Tag Out" or "Lock Out" all power sources.
- 7) Do not attempt to remove any parts without first relieving the entire system of pressure.
- 8) Do not attempt to service any part while System is in an operational mode.
- 9) Do not operate the System at pressures in excess of its rating.
- 10) Do not operate compressor at speeds in excess of its rating.
- 11) Periodically check all safety devices for proper operation. Do not change pressure setting or restrict operation in any way.
- 12) Be sure no tools, rags or loose parts are left on the Nitrox System.
- 13) Do not use flammable solvents for cleaning the Air Inlet Filters or elements and other parts.
- 14) Exercise cleanliness during maintenance and when making repairs. Keep dirt away from parts by covering parts and exposed openings with clean cloth or Kraft paper.
- 15) Do not operate the compressor without guards, shields, and screens in place.
- 16) Do not install a shut-off valve in the compressor discharge line, unless a pressure relief valve, of proper design and size, is installed in the line between the compressor unit and shut-off valve.
- 17) Do not operate in areas where there is a possibility of inhaling carbon monoxide, carbon dioxide, nitrogen, or flammable or toxic fumes.
- 18) Be careful when touching the exterior of a recently run electric, gasoline, or diesel motor - it may be hot enough to be painful or cause injury. With modern motors this condition is normal if operated at rated load - modern motors are built to operate at higher temperatures.
- 19) Inspect unit daily to observe and correct any unsafe operating conditions found.
- 20) Do not "play around" with compressed air, nor direct air stream at body, because this can cause injuries.
- 21) Compressed air from this machine absolutely must not be used for food processing or breathing air without adequate downstream filters, purifiers and controls and periodic air quality testing.
- 22) Always use an air pressure-regulating device at the point of use, and do not use air pressure greater than marked maximum pressure.
- 23) Check hoses for weak or worn conditions before each use and make certain that all connections are secure.

The user of any Compressor or Membrane System manufactured by NuVair is hereby warned that failure to follow the preceding Safety and Operation Precautions can result in injuries or equipment damage. However, NuVair does not state as fact or does not mean to imply that the preceding list of Safety and Operation Precautions is all-inclusive, and further that the observance of this list will prevent all injuries or equipment damage.

#### **4.0 Legal Precautions**

It is highly recommended that a Nitrox fill log be maintained when filling Scuba cylinders to document the following information. This log must be of permanent binding style with no loose pages.

- ◆ Fill date and time of day
- ◆ Tank Number
- ◆ Supplier's check of oxygen content (%O<sub>2</sub>) plus signature and date
- ◆ User's check of oxygen content (%O<sub>2</sub>) plus signature and date
- ◆ Fill Pressure
- ◆ MOD (Maximum Operating Depth) in user's handwriting
- ◆ Nitrox certifying agency and card number

## 5.0 Theory of Operation

The LP 280 Nitrox Generator™ is a turnkey package that produces oxygen-rich air (Nitrox) for delivery to the intake of a separate High Pressure (HP) Compressor. This HP Compressor then compresses the Nitrox to fill Scuba Cylinders or Storage Tanks. Although it is described as the “Nitrox Compressor”, it is also used to pump air.

The Nitrox System allows for efficient and cost effective Nitrox production without the hazards or expense of blending with stored high-pressure oxygen (O<sub>2</sub>). Instead, the system uses a Semi-Permeable Membrane to produce Nitrox from air. A portion of the nitrogen in air is separated out, leaving an oxygen rich Nitrox mixture. This Nitrox mixture can be pumped up to a maximum pressure of 3600 P.S.I. (250 bar) when filling Scuba Cylinders or Storage Tank.

The Nitrox System uses an LP Rotary Screw Compressor, Air Aftercooler, Refrigerated Air Dryer and Filtration to provide the Membrane System with a source of clean, pressurized air for separation. The air is filtered to CGA Grade D air quality prior to entering the Membrane System so it will not damage or plug the Membrane fibers. Specifications for Grade D air are provided in the Appendix.

The LP280 Membrane System is rated for a maximum supply pressure of 300 P.S.I. (20 bar) and works well with the 190PSI (13 bar) maximum pressure from the Rotary Screw Compressor. An Input Back Pressure Regulator reduces these input pressures to appropriate levels for Nitrox production. The air is then heated to a temperature that provides stability over a wide range of ambient conditions, is optimal for membrane permeation and provides protection to the membrane from condensate.

The heated air enters the Membrane, which is made up of thousands of miniature hollow fibers. The walls of these fibers are semi-permeable and designed for different gases to move through them (or permeate) at different speeds. The resulting gas mixture is known as the “permeate”. As air flows through the hollow fibers, both oxygen and nitrogen permeate through the fiber walls. The oxygen permeates faster than the nitrogen, which produces permeate with an oxygen content greater than air. The gas that reaches the end of the hollow fibers without permeating is almost entirely nitrogen and is discharged. The flow rate of this discharge is set by the factory via a fixed orifice, which controls the permeate to contain a constant 44% O<sub>2</sub> under normal operating conditions.

The permeate is a concentrated mixture that must be diluted with additional air prior to entering the Nitrox Compressor. It exits the Membrane at ambient to slightly negative pressure and travels into the Mixing Tube, where it mixes homogeneously with filtered outside air. The amount of dilution, and thus final %O<sub>2</sub>, is obtained by adjusting the Input Back Pressure Regulator. As input pressure is increased, permeate flow increases, air flow decreases, and a higher %O<sub>2</sub> Nitrox is produced. As input pressure is decreased, permeate flow decreases, air flow increases, and a lower %O<sub>2</sub> Nitrox is produced. This relationship between permeate flow and air flow exists because the total of these two flow rates will always equal the intake flow rate demanded by the Nitrox Compressor. The resulting Nitrox mixture is analyzed for %O<sub>2</sub> before entering the Nitrox Compressor for approximate content and again when pumping Nitrox for precise content.

A unique feature of Nuvair Nitrox Systems is that the input pressure that correlates to a specific Nitrox %O<sub>2</sub> is repeatable. For example, if your Nitrox Compressor pumps 36% O<sub>2</sub> when the input pressure is at 125 P.S.I. (9 bar), then adjusting the Regulator to 125 P.S.I. (9 bar) during the next use will produce the same mixture.



## 6.0 Low Pressure Rotary Screw Compressor Technical Data

### Capacity and Power Consumption:

- ◆ Normal working pressure – 80-175 P.S.I. (5.5-12 bar)
- ◆ Capacity at normal working pressure – 29.8 cfm (850 l/min)
- ◆ Shaft power at normal working pressure – 10.2 hp (7.65 kW)
- ◆ Maximum working pressure – 190 P.S.I. (13 bar)
- ◆ Minimum working pressure – 44 P.S.I. (3 bar)
- ◆ Idling shaft power consumption – 2.3 hp (1.7 kW)
- ◆ Transmission – Belt drive

### Cooling:

- ◆ Allowed ambient temperature – 32-104°F (0-40°C)
- ◆ Compressed air temperature above cooling medium temperature – 50°F (10°C)
- ◆ Cooling air flow – 635 cfm (0.3 m<sup>3</sup>/s)
- ◆ Maximum cooling air pressure drop – 0.12 in H<sub>2</sub>O (30 Pa)
- ◆ Cooling air temperature rise – 64°F (18°C)
- ◆ Oil cooler heat rejection – 324 BTU/min (5.7 kW)
- ◆ Aftercooler heat rejection – 40 BTU/min (0.7 kW)

### Motor and Electrical Values:

- ◆ Motor - F class, IP55, 10hp (7.5 kW)
- ◆ Speed of rotation – 2920 rpm
- ◆ Fuse (max) – 25 A
- ◆ Compressor current – 16 A at 380 V / 50 Hz
- ◆ Control voltage – 230 V

### General Technical Data:

- ◆ Oil Capacity 4 liters
- ◆ Maximum Oil Content in Air– 3 mg/m<sup>3</sup>
- ◆ Noise level (Cagi Pneurop) - 69dB
- ◆ Compressor weight – 792 lb (360 kg)

## 7.0 System Components

- Low Pressure Rotary Screw Compressor
- Nuvair 546™ Food Grade Rotary Screw Compressor Lubricant
- Refrigerated Air Dryer
- On/Off Flow Valve
- Input Back Pressure Regulator with Pressure Gauge:
  - ◆ Pressure Input to Regulator 80-189 P.S.I. (5.5-13 bar)
  - ◆ Output Pressure from Regulator 80-175 P.S.I. (5.5-12 bar) depending on HP Compressor size and Nitrox %O<sub>2</sub>
- Low Pressure Filtration, Grade D Breathing Air, including three stages:
  - ◆ Coalescing & Particle Removal to 1 micron, auto drain, differential pressure indicator
  - ◆ Water & Oil Vapor Removal to 0.01 micron, auto drain, differential pressure indicator
  - ◆ Oil Vapor Removal to 0.003 PPM, manual drain
- Heater including:
  - ◆ Thermostat Control
  - ◆ Digital Temperature Gauge
  - ◆ Pressure Switch
- Semi-Permeable Membrane – compatible with HP Compressors rated up to 10 cfm (283 L/min)
- Mixing Tube & Air Intake Filter
- Nuvair Pro O<sub>2</sub> Remote™ Panel Mount Inline Oxygen Analyzer
- Compressor Intake Hose for Nitrox Compressor
- Nitrogen Discharge Hose (optional)
- Nuvair Pro O<sub>2</sub>™ Fill Oxygen Analyzer, including:
  - ◆ High Pressure>Low Pressure Regulator
  - ◆ Flow Restrictor, 1 - 5 L/min
- Nitrox Compressor Lubricant:
  - ◆ Nuvair 455™ Food Grade Lubricant (standard)
  - ◆ Nuvair 751™ Diester Based Lubricant (optional)
- Air/Nitrox Quality Analysis Kit

## 8.0 Nitrox System Specifications

Nuvair Nitrox Generator Model		LP 280 50 Hz	LP 280 60 Hz
Physical Specifications	Height	45.6 in (1160 mm)	45.6 in (1160 mm)
	Width	47.6 in (1210 mm)	47.6 in (1210 mm)
	Depth	33.5 in (851 mm)	33.5 in (851 mm)
	Weight	792 lb (360 kg)	792 lb (360 kg)
Full Load Amps	Total Requirement for LP Compressor & Membrane Heater	21 A @ 380 VAC, 37 A @ 220 VAC, 50 Hz	37 A @ 220 VAC, 60 Hz
Membrane Input	Operating Pressure Range	80-175 psi (6-11 bar)	80-175 psi (6-11 bar)
	Maximum Input Pressure	300 psi (21 bar)	300 psi (21 bar)
	Supply Air Volume Range	8-32 scfm (212-736 L/min)	8-32 scfm (212-736 L/min)
	LP Supply Air Quality	Grade D	Grade D
	Optimum Temperature	110 +/- 5°F (43 +/- 3°C)	110 +/- 5°F (43 +/- 3°C)
	Nitrox %O <sub>2</sub> Range	24 - 40%	24 - 40%

### Nitrox Compressor Recommendations

		To Pump Nitrox up to 40%O <sub>2</sub>	To Pump Nitrox up to 36%O <sub>2</sub>	To Pump Nitrox up to 32%O <sub>2</sub>
HP Nitrox Compressors	Charging Rate	6-10 scfm (170-280 L/min)	6-14 scfm (170-400 L/min)	6-18 scfm (170-510 L/min)
	Horsepower – Electric	5-7.5 hp (3.8-5.5 kW)	5-15 hp (3.8-7.5 kW)	5-20 hp (3.8-15 kW)
	Horsepower – Gas	6.5-11 hp (4.9-8.3 kW)	6.5-18 hp (4.9-14 kW)	6.5-24 hp (4.9-16 kW)
	Horsepower – Diesel	9-10 hp (6.8-7.5 kW)	9-18 hp (6.8-14 kW)	9-27 hp (6.8-20 kW)

## 9.0 Component Identification



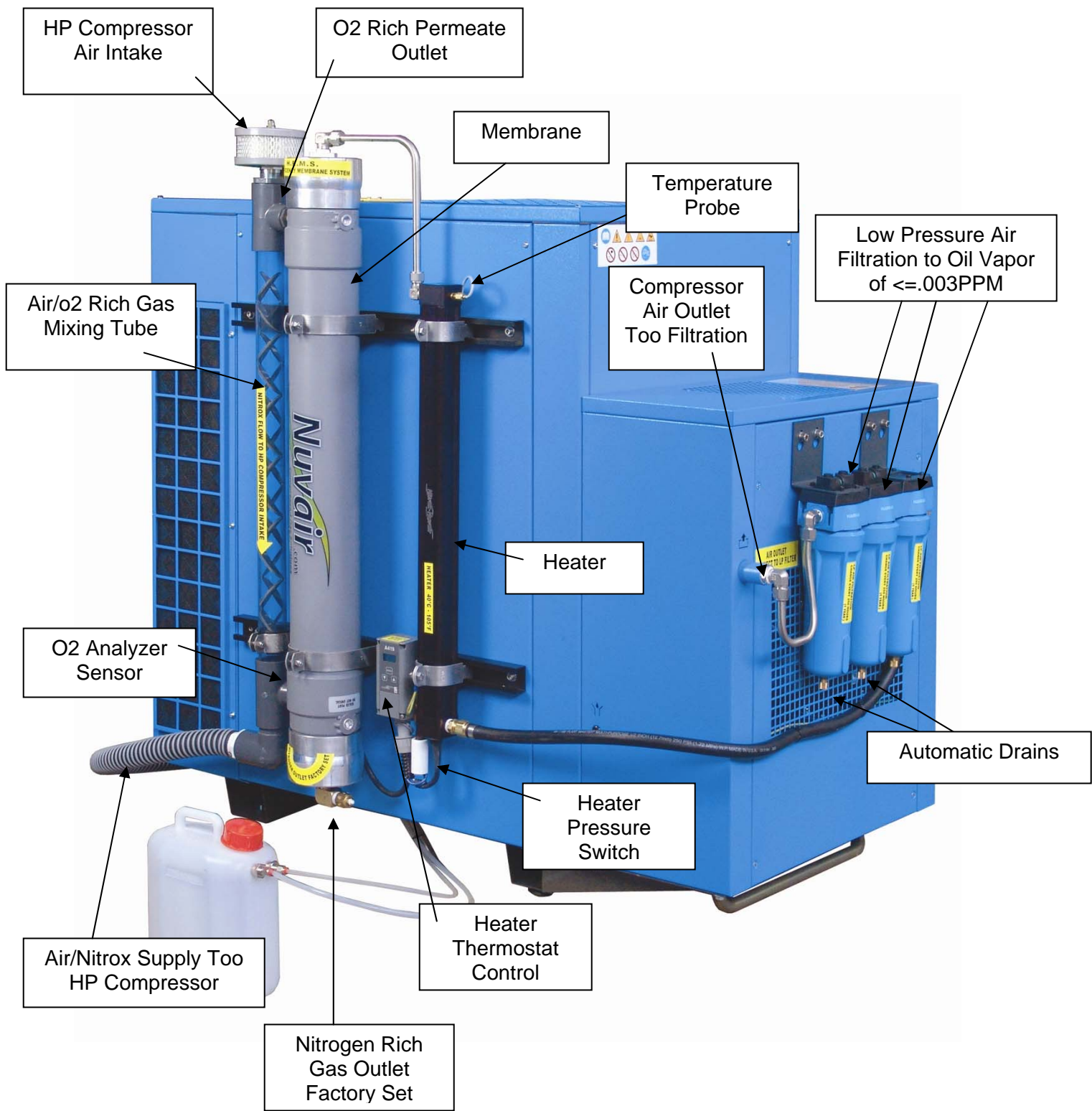

# 10.0 System Drawing / Schematic

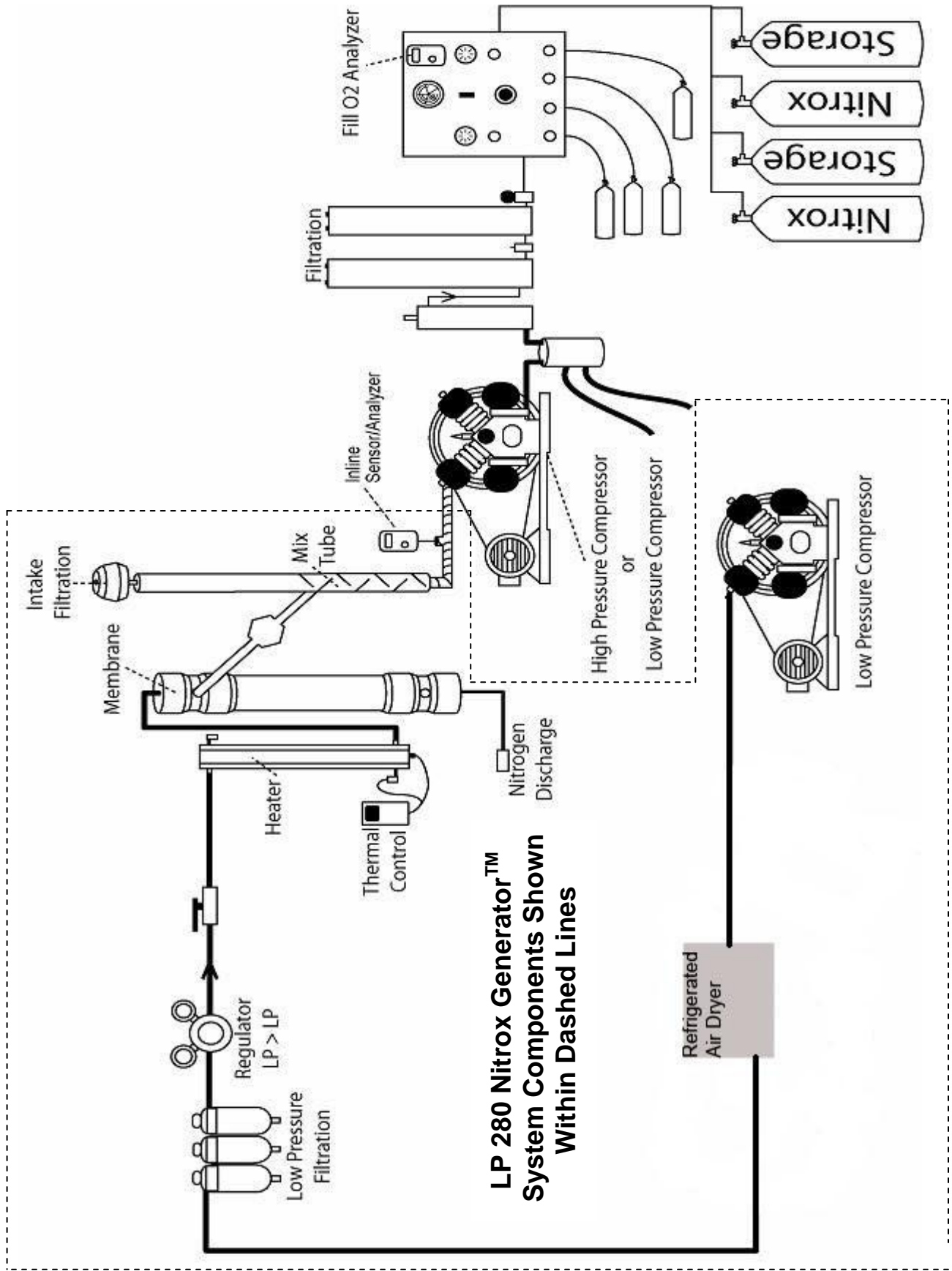

## 11.0 System Flow Chart

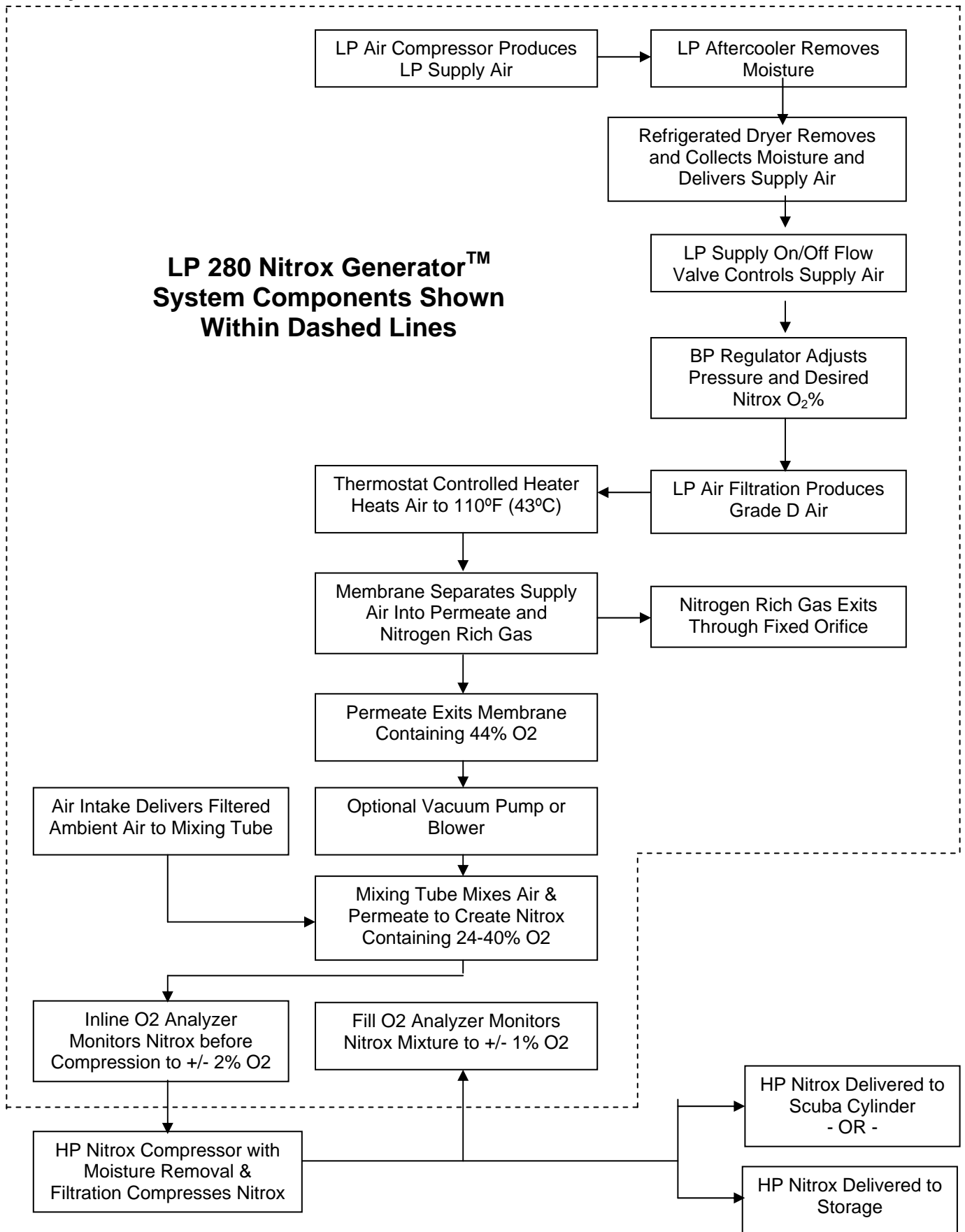

## 12.0 Preparing Existing HP Compressors



### WARNING

Some compressors are not suitable for compressing oxygen-rich air, i.e., nitrox. Use of an unsuitable compressor may lead to possible compressor damage and/or fires or explosion. This can lead to serious personal injury or death. If there is any doubt regarding the use of an existing compressor, contact Nuvair or the compressor manufacturer before you connect your Nitrox System to your machinery.

### 12.1 Purification System

The purification system on the existing HP Compressor to which the Nitrox System will be installed must produce Grade E breathing air appropriate for diving use. This is the same standard applied to all breathing air compressors. Please make sure you place extra caution on timely replacement of the filters in the purification system to ensure these standards at all times. Specifications for Grade E air are provided in the Appendix.

A recent air quality test from your existing Compressor is highly recommended prior to installing the Nitrox System. After installation, test a Nitrox sample using the Air/Nitrox Quality Analysis Kit provided. Quarterly testing is mandatory once the System is operational.



### CAUTION

Breathing air compressors must produce breathing air appropriate for diving use in accordance with the appropriate CGA Grade. Periodic air quality testing is mandatory to assure compliance.

### 12.2 Replacement of Compressor Lubricant

For an existing Compressor to be used with the Membrane System, all traces of old Lubricant must be removed and replaced with Nitrox Compressor Lubricant. Nitrox Compressor Lubricant is compatible with both air and Nitrox.

- 1) Start Compressor and run for 10 minutes to warm Compressor Lubricant. Shut off Compressor, remove Lubricant, and replace Lubricant Filter if any.
- 2) Refill Compressor with the Nuvair Air/Nitrox Compressor Lubricant supplied. Do not overfill.
- 3) After 10 hours, repeat Steps 1 and 2.



Nuvair™ 455  
Food Grade Air &  
Nitrox Compressor  
Lubricant (Standard)



Nuvair™ 751  
Diester Based Air &  
Nitrox Compressor  
Lubricant (Optional)



### CAUTION

After running the compressor, the lubricant will be very hot. Take care when removing the drain plug and draining the lubricant to avoid burns.





## NOTICE

Recommended Nitrox Compressor Lubricant change intervals after the 10-hour flush are at 25, 50, and 100 hours. After reaching 100 hrs, change lubricant in 100 hour cycles.



## CAUTION

Wear gloves when handling compressor lubricant. If contact with skin is made, wash the skin surface with soap and water.



## CAUTION

Always wear goggles when handling compressor lubricant. These materials can cause eye irritation. If you accidentally get lubricant into your eyes, flush with fresh water for 15 minutes and contact a physician if irritation develops.



## CAUTION

Compressor lubricant should be incinerated after use in a licensed facility in accordance with Federal, State, and local regulations.

### 12.3 Installation of Fill Oxygen Analyzer

The Fill Oxygen Analyzer is installed at the final nitrox outlet (compressor fill whip, Fill Panel, etc.) to monitor oxygen content. A sample stream of nitrox is delivered to the analyzer to provide accurate results and prevent damage to the analyzer. A regulator and flow restrictor are used to control the pressure and flow of the sample stream. After installation, always use the Fill Oxygen Analyzer when pumping either nitrox or air to ensure proper oxygen content.



## WARNING

Never expose the Oxygen Analyzer Sensor to pressure or you may cause damage and/or false readings. Damaged sensors will not provide accurate gas analysis. Inaccurate gas analysis can lead to serious personal injury or death.

The Nitrox sample stream is obtained at the Fill Whip location on the Compressor or Fill Panel. Tap into the Fill Whip manifold or install a HP "T" fitting, then attach the inlet of the Regulator/Flow Restrictor Assembly using HP hose and fittings as required (hose and fittings not included). Mount the Fill Oxygen Analyzer in a secure location, then attach the outlet of the Regulator/Flow Restrictor Assembly to the Analyzer using the hose provided.

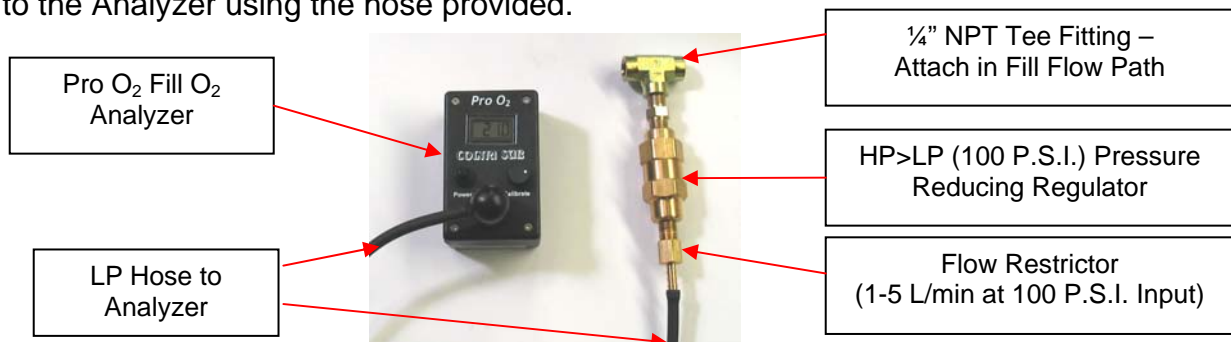

## 13.0 Installing the Nitrox System



### NOTICE

If any information in this manual conflicts with any of the other manuals call Nuvair before proceeding.



### CAUTION

**Ambient room temperature should never exceed 100°F (38°C) during operation of the Nitrox System. Operation at higher temperatures may lead to system damage and malfunction. A damaged membrane will not produce the correct nitrox mixture which can lead to severe personal injury if the gas is used for diving purposes without proper analysis.**

### 13.1 Precautions

- 1) Please read all information supplied before physically installing the Nitrox System.
- 2) Unpack the system and remove from the pallet. Visually inspect the system to make sure there has been no damage during shipping. If damaged, please call Nuvair to file a damage report. Please take photos and supply detailed information about the damage.
- 3) Place the system in a permanent location near the existing HP Compressor. Allow a minimum spacing of 18" from adjacent walls. Select a location where ambient room temperature will never exceed 100°F (38°C).
- 4) The Heater Thermostat has been set in the factory. Do not adjust.
- 5) A 13 foot corrugated Compressor Intake Hose has been provided to connect the Nitrox System to the HP Compressor intake. If a longer hose is required, the diameter must also be increased. Contact Nuvair for assistance.

Intentionally left blank.

### 13.2 Attaching Compressor Intake Hose



**WARNING**

Do not substitute a compressor intake hose of a smaller diameter or longer length than that supplied. This will increase the amount of suction the compressor must generate which can cause overheating and damage to the compressor. Damaged compressors can pump impurities into the diver's breathing gas. This may cause serious injury or death.

- 1) Cut the Intake Hose to proper length to reach between the Nitrox System and HP Compressor. Reattach end fittings
- 2) Attach the Intake Hose to the Nitrox System outlet.
- 3) Attach the other end of the Intake Hose to the intake of the Nitrox Compressor and secure with the hose clamp provided.

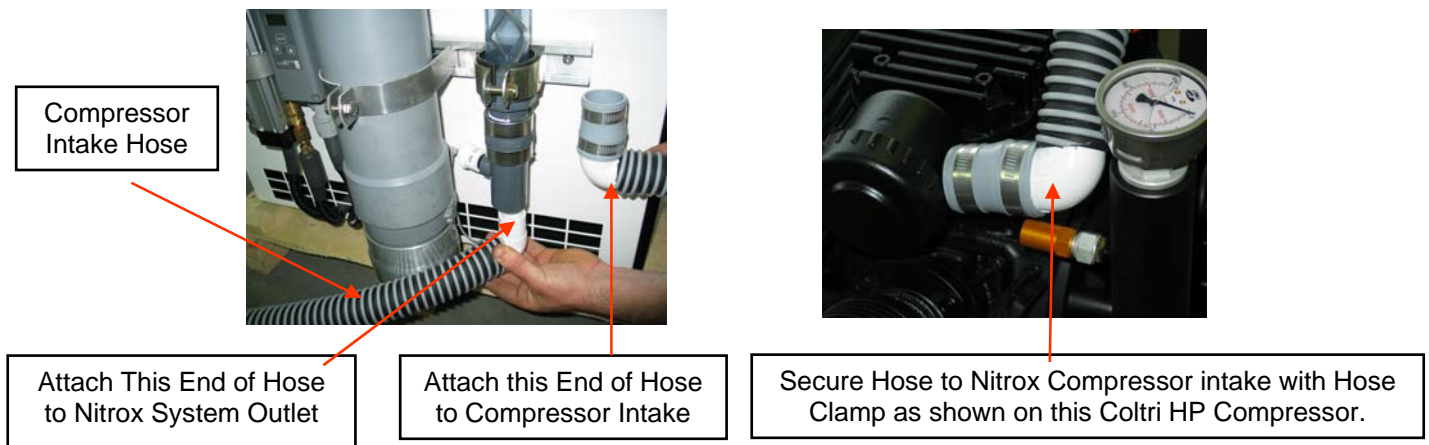

### 13.3 Attaching Nitrogen Discharge Hose (Optional)

The nitrogen discharge from the Membrane must be isolated from the air intakes of the Membrane System and LP Compressor. This requirement will be met if the Nitrox System is installed in a well-ventilated room that meets industry standards for Compressor installations. If the Nitrox System is installed in a closed building, boat, or similar enclosed space, the nitrogen discharge must be vented to the outside. An optional Nitrogen Discharge Hose may be needed. If your installation requires the use of a Nitrogen Discharge Hose, please contact Nuair for assistance.



**DANGER**

Pure nitrogen is a colorless, odorless, tasteless gas that will not support life. Breathing gas mixtures containing more than 84% nitrogen at surface pressures will lead to unconsciousness and may cause death.



**WARNING**

The nitrogen discharge from the Membrane should be vented to a well-ventilated room or to open air with good circulation. Failure to isolate the discharge from the air intake of the Membrane System or LP compressor could lead to incorrect nitrox mixtures, resulting in serious personal injury or death. If you allow this pure nitrogen to accumulate in an enclosed space, anyone entering this space will quickly lose consciousness and will die if not immediately resuscitated.

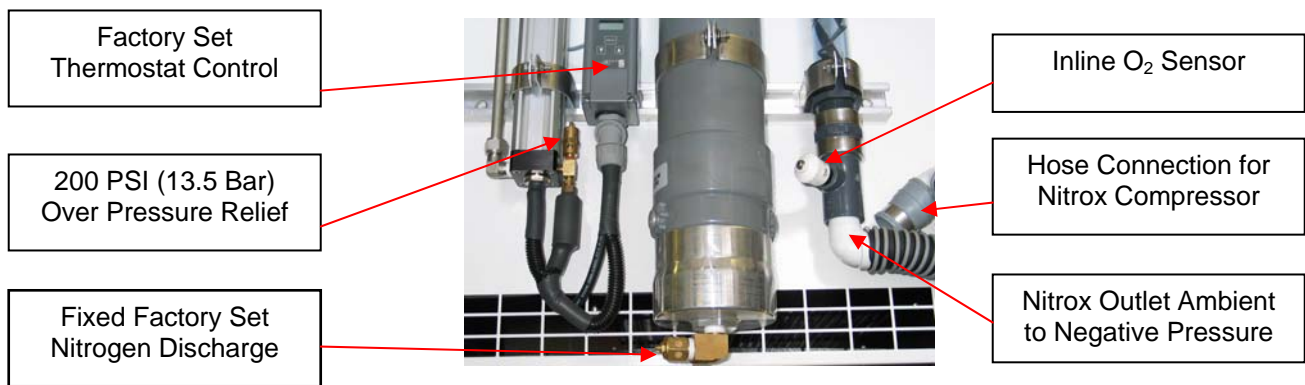

### 13.4 Output Pressure Adjustments

The LP Compressor maximum pressure has been factory set to pump up to 190 P.S.I. (13 bar) and then go idle until the pressure drops down to a low pressure of approximately 165 P.S.I. (11 bar). This cycle is known as the compressor differential pressure.

This output setting allows the system to be used with a HP Compressor having a rated capacity up to 10 cfm (283 l/m) and produce 40%.

### 13.5 Electrical Power Connection



**WARNING**

**Never use extension cords to provide power to your Nitrox System. The system must be properly wired according to national and local electrical codes by a qualified electrician. Improper wiring may lead to fires, which can cause serious personal injury or death.**

Prior to making the electrical power connection, check all system specifications provided in this manual. When working on the Nitrox System the main breaker at the power source must be “locked out” in the Off position.

### Amperage Load for System

- ◆ Approximately 37 A for 220 V three phase service
- ◆ Approximately 21 A for 380 V three phase service

### LP Compressor Rotation Check

Always turn on (bump) starter and run motor very briefly to check for proper direction of rotation (see arrow above pulley).

Proper Rotation will force exhaust air out the top and raise the test paper.



## CAUTION

**Operation in reverse direction for even a short period of time will damage a Rotary Screw Compressor.**

The Cabinet Power Switch must be in the Off position to remove the front panel of the Compressor. This Switch terminates power to the Compressor and electrical panel. Store the compressor with this switch in the Off position. **When working on the Compressor the main breaker at the power source must also be "locked out" in the Off position.** The Nitrox System has circuit breaker protection for the Compressor Motor and Membrane System Heater located behind the right side panel.



## 13.6 Air/Nitrox Quality Testing

Before using your Nitrox System to pump nitrox, test a sample of the nitrox produced using the Air/Nitrox Quality Analysis Kit provided to verify compliance with CGA standards. Quarterly testing is mandatory once the System is operational.

Air/Nitrox Quality  
Analysis Kit



## 14.0 Pre-Operation Instructions



### WARNING

Do not allow nitrox to be discharged into the air storage system. Nitrox introduced into the air storage system could cause a diver to suffer from oxygen poisoning at depth. Oxygen poisoning is extremely dangerous and can lead to drowning.



### WARNING

Do not allow air to be discharged into the Nitrox storage system. Air introduced into the nitrox storage system could cause a diver to suffer from decompression sickness if the nitrox mixture is not analyzed properly and is used underwater under the assumption it is a different mix.

### 14.1 Compressor Lubricant Levels

Check lubricant levels before starting the LP and HP Compressors, and add lubricant as required. Use only the lubricants specified.

Check LP  
Compressor Oil Level



### 14.2 Membrane System Regulator and Flow Valve

A Back Pressure Regulator is used to reduce supply pressure to the Membrane System to a typical range of 80 – 175 P.S.I. (5.5-12 bar)  
An On/Off Flow Valve is used to control the flow of LP supply air into the Membrane System. Prepare the Membrane System as follows:

- 1) Reduce input pressure setting by turning the Regulator adjustment knob counter-clockwise (CCW) a few rotations.
- 2) Make sure the LP Supply Air On/Off Flow Valve is in the Off position.

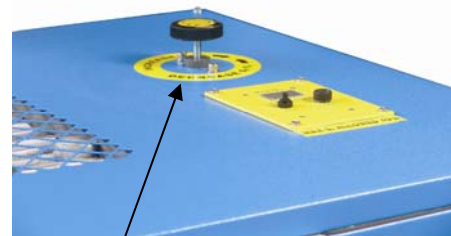

Regulator  
Adjustment Knob

On/Off Ball Valve  
shown.  
Not available on all  
systems.



### 14.3 Oxygen Analyzer Calibration

Gas production may be monitored with the Inline Oxygen Analyzer before entering the Nitrox Compressor to obtain a rough estimate of %O<sub>2</sub> (+/- 2%); however, do not rely on this reading as an indication of %O<sub>2</sub> at the Nitrox Compressor outlet. Prior to pumping nitrox into a Scuba cylinder or Surface Supply System, it must be monitored with the Fill Oxygen Analyzer to obtain a precise measurement of %O<sub>2</sub> (+/- 1%). Both Oxygen Analyzers must be calibrated prior to each use.

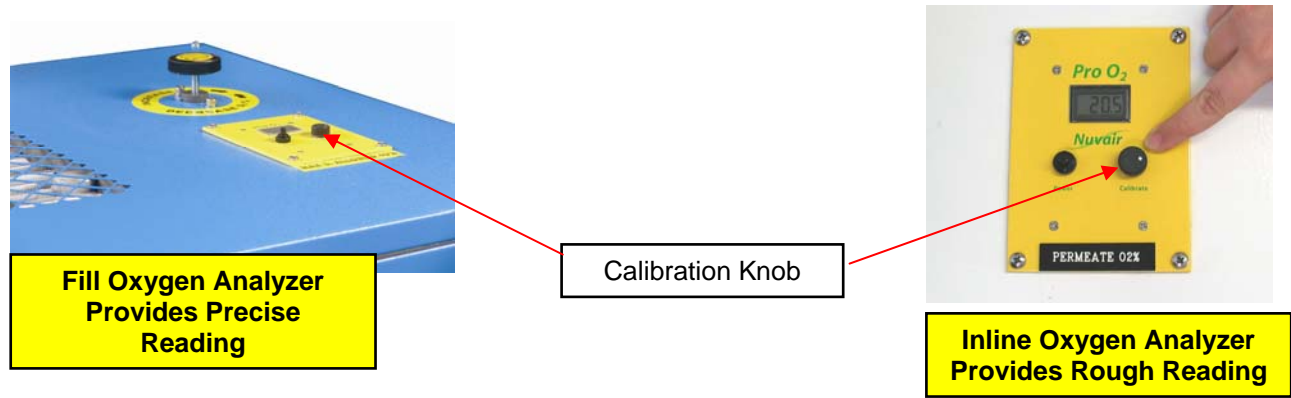

#### WARNING

Oxygen Analyzers must be calibrated before each use. See Oxygen Analyzer manuals for correct calibration procedures. Improper calibration of the Fill Oxygen Analyzer may result in the use of incorrect nitrox mixtures, which may cause serious injury or death to the diver using the gas mixture.



#### WARNING

At altitudes above sea level, a correction factor must be used when calibrating the Fill Oxygen Analyzer may not be achievable. See Fill Oxygen Analyzer manual for correcting analyzer readings at various altitudes. Improper calibration of the Fill Oxygen Analyzer may result in the use of incorrect nitrox mixtures, which may cause serious injury or death to the diver using the gas mixture.



#### WARNING

The Inline Oxygen Analyzer supplies oxygen readings that can vary +/- 2% O<sub>2</sub> due to heat, humidity, and pressure changes experienced in the nitrox flow and therefore should only be used for rough estimates of %O<sub>2</sub>. The Fill Oxygen Analyzer supplies more accurate oxygen readings, within +/- 1% O<sub>2</sub>. For Scuba cylinder nitrox fills, the user must always verify the final fill with a third independent Oxygen Analyzer.

Calibrate Oxygen Analyzers as follows:

- 1) Close Membrane System On/Off Flow Valve
- 2) Slightly open fill whip valve on HP Nitrox Compressor to relieve any residual pressure, and then, if desired, insert clean rag in yoke to act as sound muffler.
- 3) Turn on HP Nitrox Compressor according to manufacturer's instructions.
- 4) Adjust fill whip valve so the running Compressor maintains 1500-2000 P.S.I. outlet pressure. Air will now be flowing past both Oxygen Analyzers for calibration purposes.

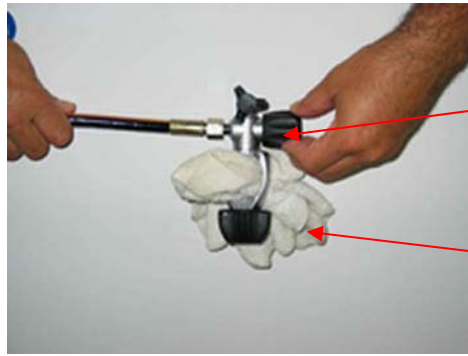

Adjust Fill Whip Valve to Maintain Pressure

Insert Clean Rag in Fill Whip Yoke

Optional Sound Muffler for HP Nitrox Compressor

- 5) Monitor all gauges for proper operating range and check all connections for leaks.
- 6) Calibrate Oxygen Analyzers while the Nitrox Compressor is pumping air. Refer to the Oxygen Analyzer manual included with the Nitrox System for details. Note that special calibration procedures may be required when operating at altitudes above sea level.
  - ◆ Inline Oxygen Analyzer - Calibrate Analyzer so Display reads 20.9%.
  - ◆ Fill Oxygen Analyzer - Calibrate Analyzer so Display reads 20.9% to correlate with the Grade E breathing air present at the Sensor. Different settings may be used depending on location, so verify your actual ambient conditions and refer to the Oxygen Analyzer manual for details.

Fill Oxygen Analyzer - Alternate Calibration Method

The Fill Oxygen Analyzer can also be calibrated in ambient air as an alternative. This is especially useful during routine re-calibration while the system is operating. Different settings may be used depending on location, so verify your actual ambient conditions and refer to the Oxygen Analyzer manual for details.

- 1) Remove the Flow Adapter Cap covering the Sensor.
- 2) Expose the Sensor to ambient air for approximately 15 seconds.
- 3) Adjust Calibration Knob until Display reading stabilizes at 20.9%.
- 4) Reinstall the Flow Adapter Cap to the Analyzer.
- 5) The Fill Oxygen Analyzer is now ready for use.



Sensor Cap Removed

Calibration Knob

**14.4 Attaching Scuba Cylinder**



**Only one fill whip is attached to a Scuba Cylinder at this point. The second whip will continue to be used to control HP compressor outlet pressure.**

Attach one HP compressor Fill Whip to a Scuba Cylinder. Leave Cylinder Valve closed.

Additional cylinders or storage tanks can be attached after the system is ready to pump Nitrox.

Fill Whip Attached to Scuba Cylinder

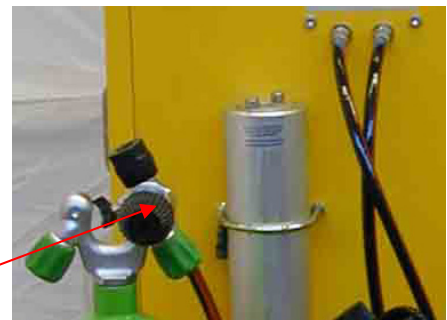



## 15.0 Producing Nitrox



### WARNING

The equipment you will be using to manufacture nitrox (oxygen rich air) will expose you to both low and high-pressure gas. Gas, even under moderate pressures, can cause extreme bodily harm. Never allow any gas stream to be directed at any part of your body.

### 15.1 Flow to Membrane

- 1) Verify that Oxygen Analyzer calibration is complete.
- 2) Turn on LP Compressor using On/Off Switch.
- 3) Turn on your HP Compressor. Allow outlet pressure to build up to approximately 2300 P.S.I., then crack open the unconnected fill whip to maintain 1500-2300 P.S.I.
- 4) Verify that Inline Oxygen Analyzer reads 20.9%.
- 5) Turn on Membrane System by slowly opening the Flow Valve.
- 6) Adjust input pressure to approximately 100 P.S.I to activate Heater Pressure Switch. Increase pressure by slowly turning the Regulator Knob CW or decrease pressure by turning the Knob CCW.
- 7) Verify that Heater Thermostat Control green indicator light is on. The light will remain on until operating temperature is reached and will then cycle on and off. When light turns off, check Heater Temperature Gauge to verify air temperature is between 105-120 °F (40-49 °C). Temperature is preset at the factory and changes to the Thermostat Control should not be required.

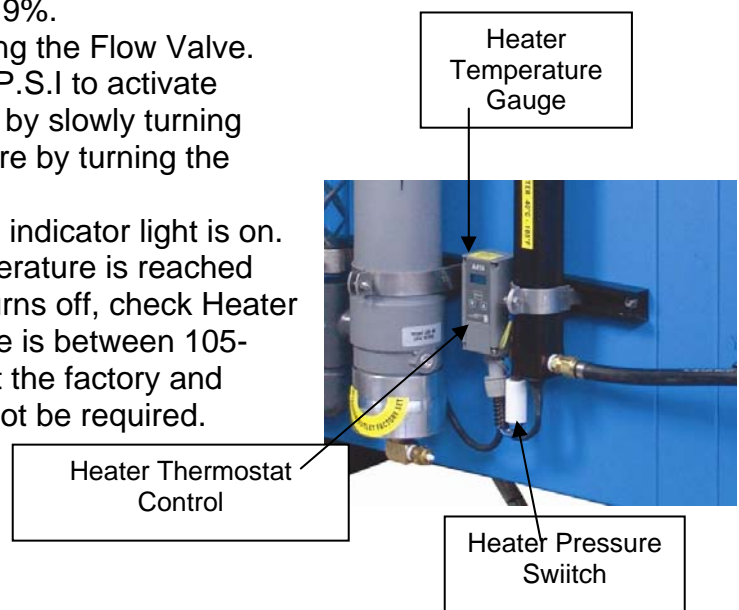

### CAUTION

The On/Off Flow Valve on the Membrane System must be opened slowly. A sudden rush of gas can damage the Membrane and other system components. A damaged membrane will not produce the correct nitrox mixture which can lead to severe personal injury if the gas is used for diving purposes without proper analysis.



### NOTICE

The Heater Thermostat Control green indicator light will stay on until operating temperature is reached.



## CAUTION

**Do not change the temperature setting on the Thermostat Control without contacting Nuvair. Changes in temperature settings may cause Membrane damage. A damaged membrane will not produce the correct nitrox mixture which can lead to severe personal injury if the gas is used for diving purposes without proper analysis.**

### 15.2 Setting Proper Pressure

The input pressure to the Membrane System determines the %O<sub>2</sub> of the Nitrox mixture produced. As input pressure is increased, a higher %O<sub>2</sub> Nitrox is pumped. As pressure is decreased, a lower %O<sub>2</sub> Nitrox is pumped.

- 1) Increase input pressure by slowly turning the Regulator knob CW while monitoring the Pressure Gauges and Inline Oxygen Analyzer. As the pressure rises, watch the corresponding increase in the Analyzer %O<sub>2</sub> reading.
- 2) Increase or decrease pressure slowly until the Inline Oxygen Analyzer displays the %O<sub>2</sub> desired in the final Nitrox mixture.
- 3) Allow system pressure and temperature to stabilize (approximately 5-8 minutes).
  - ◆ Regulated Membrane System pressure range should be 80– 175 P.S.I (5.5-12 bar), depending on Nitrox %O<sub>2</sub> being produced.
  - ◆ Heater temperature range should be 105-120 °F (40-49 °C).



Inline Oxygen Analyzer



## NOTICE

### 15.3 Final Adjustments Before Pumping Nitrox

- 1) As the Nitrox initially makes its way through the running Nitrox Compressor, the %O<sub>2</sub> reading on the Fill Oxygen Analyzer will slowly increase to read approximately the same %O<sub>2</sub> as the Inline Oxygen Analyzer. This should happen within 3-5 minutes.
- 2) When the two Analyzers read within +/- 1%, make any final adjustments to the Membrane System input pressure necessary to obtain the exact Nitrox %O<sub>2</sub> desired as indicated on the Fill Oxygen Analyzer.
- 3) The system is now ready to pump Nitrox.

Fittings and HP>LP Regulator. Attach to existing HP Fill Panel



Fill Oxygen Analyzer

## 15.4 Pumping Nitrox



### WARNING

The use of enriched air nitrox does not eliminate the risk of decompression sickness (DCS) in diving. Decompression sickness can lead to permanent disability or death.



### WARNING

The Inline O<sub>2</sub> Analyzer supplies oxygen readings that can vary +/- 2% O<sub>2</sub> due to heat, humidity, and pressure changes in the nitrox flow and should only be used for rough estimates of %O<sub>2</sub>. The Fill O<sub>2</sub> Analyzer supplies more accurate readings, within +/- 1% O<sub>2</sub>. For Scuba cylinder nitrox fills, the user must always verify the fill with a third independent O<sub>2</sub> analyzer.



### WARNING

Do not use this system to produce nitrox mixtures containing more than 40% oxygen. Pumping nitrox mixtures with higher concentrations of oxygen may lead to fires or explosions, which can cause serious personal injury or death.



### WARNING

Do not pump nitrox mixtures at pressures above the compressor rating, and never above 3600 P.S.I. (250 bar). The system is not rated for pressures above 3600 P.S.I. (250 bar). Higher pressures may lead to explosions which may cause serious personal injury or death.



### NOTICE

No oxygen cleaning of standard cylinders or plumbing is mandatory when using the Nitrox System to produce nitrox containing a maximum of 40% oxygen. When filling oxygen clean cylinders, hyper-purification of the nitrox is required using an optional Oxygen Compatible Air purification system available from Nuvair.



### DANGER

This Nitrox System does not produce nitrox mixtures acceptable for 100% oxygen service.



### DANGER

Never fill a cylinder that is marked, "For Oxygen Service," with nitrox that has been produced by anything other than 100% oxygen clean system. Filling an oxygen clean cylinder with breathing gas containing hydrocarbons can lead to explosions if the cylinder is subsequently filled with gas mixtures containing gas mixtures containing greater than 40% oxygen.



### WARNING

Only provide Scuba cylinder nitrox fills to customers who have proof of nitrox training and certification. Improper use of nitrox can be fatal.



### DANGER

This system is not cleaned for oxygen service and not all components are compatible with gas mixtures containing greater than 40% oxygen. Pumping gas mixtures containing greater than 40% oxygen will lead to explosions which may cause severe personal injury or death.



## WARNING

Each Scuba cylinder belonging to a customer must be analyzed by that customer at the nitrox filling facility, using an oxygen analyzer independent of those used with the Nitrox System. An employee must witness that the customer has properly analyzed the gas in each cylinder, noted the maximum operating depth for that mixture, and signed and dated the fill log. The time of day must also be included with the date, since some customers may fill the same cylinder more than once a day.

Fill Scuba Cylinders or HP Storage tanks as follows:

- 1) When filling a Nitrox Scuba cylinder, follow all industry standards. Do not exceed rated pressure of cylinder, and do not exceed 3600 P.S.I. under any condition.
- 2) With fill whip bleed valve open and Nitrox flowing, verify that Fill Oxygen Analyzer %O<sub>2</sub> reading equals the desired Nitrox %O<sub>2</sub>.
- 3) Close bleed valve, open cylinder valve, and fill cylinder. While filling, monitor system for proper operation:
  - a) Monitor Oxygen Analyzers and recalibrate as required
  - b) Manually drain all Compressor condensate periodically or listen for proper operation of auto-drains if equipped.
  - c) Monitor all system gauges as shown in the table below.



## NOTICE

The Oxygen Analyzers may require re-calibration after 10-20 minutes of operation due to humidity and temperature change effects on the Sensor. To recalibrate, turn off the Membrane System On/Off Flow Valve and follow calibration instructions.



## NOTICE

When the HP compressor auto drain engages and dumps condensate, the Fill Oxygen Analyzer reading will decrease momentarily due to the pressure drop in the system. It will return to its previous reading within seconds after the auto drain sequence stops.

<i>GAUGE</i>	<i>RECOMMENDED SETTING</i>
Compressor Gauges	According to manufacturers recommendations
Heater Temperature	105-120° F (40-49° C)
Cabinet Temperature	Less than 100 ° F (38 °C)
Compressor Outlet Pressure	0-190 PSI (13 bar)
Regulated Pressure to Membrane	80 – 175 PSI (6-11bar) depending on Nitrox O <sub>2</sub> % .
Fill Oxygen Analyzers	Showing the proper reading for intended fill
Nitrox Storage Pressure	<b><u>DO NOT</u></b> exceed rating of tank or 3600PSI (250Bar)

- 4) After filling is complete, close cylinder valve, vent the bleed valve, and remove the cylinder.

- 5) Test the nitrox %O<sub>2</sub> in the cylinder using an independent Oxygen Analyzer such as the Nuair O<sub>2</sub> Quickstick™. Calibrate analyzer before use in accordance with manufacturer's instructions.
- 6) Repeat steps 1-5 until you have filled all Scuba cylinders.
- 7) Mark each tank with fill date, %O<sub>2</sub>, fill pressure, and MOD (Maximum Operating Depth).
- 8) Log every Nitrox fill to document the following information:
  - ◆ Fill date and time of day
  - ◆ Tank Number
  - ◆ Supplier's check of oxygen content (%O<sub>2</sub>) plus signature and date
  - ◆ User's check of oxygen content (%O<sub>2</sub>) plus signature and date
  - ◆ Fill Pressure
  - ◆ MOD (Maximum Operating Depth) in user's handwriting
  - ◆ Nitrox certifying agency and card number
- ◆ When filling a HP Nitrox storage tank, verify that Fill Oxygen Analyzer %O<sub>2</sub> reading equals the desired nitrox %O<sub>2</sub>. Open applicable line valves and tank valve, and fill with nitrox. Do not exceed rated pressure of cylinder, and do not exceed 3600 P.S.I. (250 bar) under any condition. After filling is complete, close all valves and turn off compressor or relieve pressure.



Use Independent Oxygen Analyzer for Verification

## 15.5 Pumping Air

To use the System to pump air, simply move the On/Off Flow Valve to the Off position. No Nitrox will be supplied to the HP Compressor, and it will pump air only. Both the Inline Oxygen Analyzer and Fill Oxygen Analyzer should read 20.9% when the HP Compressor is pumping air.



### NOTICE

**Always use Oxygen Analyzers to monitor oxygen content of any gas flowing through the System. Both air and Nitrox are subject to variations in oxygen content.**



On/Off Flow Valve Handle in Off Position

## 15.6 Shutting Down

- 1) Shut off the Membrane System by turning the Regulator adjustment knob CCW to reduce input pressure to minimum setting and then closing the On/Off Flow Valve.
- 2) Manually drain all filter, Compressor, and Volume Tank condensate drains.
- 3) Turn off LP Compressor On/Off Switch. The Compressor will go into shut down mode.
- 4) Turn off HP Compressor when it has returned to pumping air, as determined by a Fill Oxygen Analyzer reading close to 20.9% O<sub>2</sub>.

## 16.0 Nitrox Operation Notes

### 16.1 Correlation of Input Pressure to Oxygen Content

After the 10 hour break-in period for your Nitrox System, you will notice that specific nitrox %O<sub>2</sub>'s always match specific input pressures once the System has warmed up. These pressures will be repeatable. If you find that the Fill Oxygen Analyzer reads 36% O<sub>2</sub> when the input pressure is at 125 P.S.I. (9 bar), record this pressure or make a mark on the input pressure gauge indicating the %O<sub>2</sub>. Do this for each %O<sub>2</sub> that you normally make, making sure System has warmed up first. The next time nitrox with 36% O<sub>2</sub> is needed, adjust the regulator to 125 P.S.I. (9 bar) and wait for the Oxygen Analyzer reading to stabilize. You will find the analyzer reading to be very close to 36% O<sub>2</sub>, requiring only minor adjustments of the regulator to achieve the exact desired %O<sub>2</sub>.



#### NOTICE

**Use the Fill Oxygen Analyzer to verify the nitrox oxygen percentage prior to pumping. When using the input pressure reading to obtain specific oxygen percentage, minor adjustments of the input pressure regulator may be required to obtain the exact percentage desired.**

### 16.2 Hot Fills

While in the process of filling HP Nitrox Storage Tanks, you may have a need to supply a walk-in customer with a Scuba Cylinder fill of a different nitrox mix. You can change mixes as follows:

- 1) With the Nitrox System and HP compressor operating, isolate the HP Nitrox Storage Tanks from the HP compressor by closing appropriate valves.
- 2) Record the Membrane System input pressure reading
- 3) Slightly open fill whip valve on the HP compressor, and adjust so the running compressor maintains 1500-2000 P.S.I. (100-140 bar) outlet pressure.
- 4) Adjust the input regulator to the pressure corresponding to the desired nitrox %O<sub>2</sub> for the Scuba Cylinder fill.
- 5) Allow the Fill Oxygen Analyzer reading to stabilize, make any minor adjustments necessary to achieve the desired %O<sub>2</sub>, and then fill cylinder in normal manner.
- 6) When finished return regulator to previous setting, and allow the Fill Oxygen Analyzer reading to stabilize. Make any minor adjustments necessary to achieve the desired %O<sub>2</sub>, and then resume filling Storage Tanks.

## 17.0 Maintenance

The following list of daily and routine maintenance items is intended as a guide. Refer to LP and HP Compressor manuals for complete maintenance requirements.

### 17.1 Daily Maintenance



#### CAUTION

**Be sure to check compressor lubricant level prior to each day of operation. Failure to ensure the proper lubricant level will lead to system damage.**

- 1) Check Lubricant levels of both LP and HP Compressors and add proper Lubricants as required. See Section 14.1 and Compressor manuals for details.
- 2) Check HP Compressor Filtration for condensate and proper operation of condensate drains. Refer to HP Compressor manual for details.
- 3) Check LP Filtration for condensate and proper operation of condensate drains.

### 17.2 Routine Maintenance



#### WARNING

**Use only the specified Nuvair Lubricants in this system. The use of incompatible lubricants presents a risk of fire and/or explosion, and may result in system damage. This can lead to severe personal injury and death.**



#### WARNING

**Be sure that all pressure has been relieved from the system prior to opening any filtration canister. Failure to vent pressure from the system prior to opening the canister can lead to serious personal injury or death.**



#### CAUTION

**If system is located in an area where there is high humidity and high heat, the life of all Filtration Elements may be as little as 35% of rated operating capacity. Check the compressor manual and Appendix for details on Filter Element Life Factors.**

- 1) LP Compressor Lubricant: Change Rotary Screw Compressor Lubricant and Lubricant Filter after the first 100 hour break in period and every 1500 hours thereafter. Only use Lubricants rated for use with Rotary Screw Compressors, such as Nuvair 546™. Never mix Compressor Lubricants. See Section 17.3 and LP Compressor manual for details.
- 2) LP Filtration Inspection: On a weekly basis, inspect each Filter Bowl for the presence of moisture and each Element for any unusual degradation or wetness. See Section 17.4 for details.
- 3) LP Filtration Elements: Change LP Filter Elements every 100 hours to maintain CGA Grade D air standards. Visual differential pressure (DP) indicators on the HF7 and HF5 filters assist with monitoring replacement intervals. See Section 17.4 for details. If the Nitrox System is operated in

high humidity and/or high temperature, Filter Elements must be changed more often. See Appendix for details on Filter Element Life Factors.

- 4) Semi-Permeable Membrane: No maintenance required. Service life exceeds 20 years if LP Filtration is properly serviced to maintain Grade D standards.
- 5) Membrane System Air Intake Filter: Inspect filter element every 3 months for visible particles. Change every 12 months or sooner if particles are visible.
- 6) Oxygen Analyzers: Replace Oxygen Sensor and Battery as required. See manual included with Nitrox System.



**DANGER**

**Do not swallow (ingest) either the electrolyte from the Oxygen Sensor or the Sensor itself. The Potassium Hydroxide chemical contained in the Sensor can cause severe injury or death. If electrolyte or the Sensor is swallowed, seek medical attention immediately.**



**DANGER**

**If after handling the Oxygen Analyzer or Sensor, you find that your fingers or other parts of your body feel “slippery” or the skin or eyes sting, immediately flush affected area with clean, fresh water for at least 15 minutes. The stinging or slippery sensation is an indication of a leaking Sensor. The Potassium Hydroxide chemical contained in the Sensor can cause severe injury or death. Seek immediate medical attention if eye contact is made or skin stinging persists.**

The following items are not integral parts of the Nitrox System, but proper maintenance is required to assure optimum performance.

- 1) HP Compressor Lubricant: Change HP Compressor Lubricant every 100 hours of operation in accordance with manufacturer’s guidelines. Only use Lubricants rated for use with Nitrox, such as Nuvair 455™ or 751™. Never mix Compressor Lubricants. Refer to HP Compressor manual for details.
- 2) Breathing Air Filters: Change HP Compressor Filter Elements in accordance with manufacturer’s guidelines to maintain CGA Grade E breathing air standards.
- 3) Air/Nitrox Quality Analysis: Take breathing air/Nitrox samples quarterly for analysis to assure compliance with CGA Grade E breathing air standards.



## 17.3 Compressor Lubricant

The LP Rotary Screw Compressor in your Nitrox System uses Nuvair 546™ Food Grade Synthetic Rotary Screw Compressor Lubricant. This lubricant is thinner than the lubricants that are used in reciprocating HP Compressors and should not be mixed with other Compressor Lubricants.

Access to the oil filter, oil/air separator and oil drains is through the front cabinet door. See appendix page 38

# NUVAIR™ 546

## FOOD GRADE ROTARY SCREW COMPRESSOR OIL

### Application

Nuvair™ 546 is designed for 2,000 hours of use in rotary screw compressors where a food grade lubricant is needed. USDA H-1 rated Nuvair™ 546 meets all requirements under FDA Regulation 21 CFR 172.878 and 178.3570.



### Characteristics:

- Available in quart, gallon, and five-gallon containers
- Improved thermal and oxidative stability over mineral oil
- Compatible with most seals, plastics, rubbers
- Wide operating temperature range
- Non-detergent
- Extended drain intervals reduces oil disposal, thus increasing cost effectiveness

### Typical Properties

SAE Grade  
 ISO Viscosity Grade  
 Viscosity, cSt @ 100°F  
 cSt @ 210°F  
 Viscosity Index  
 Pour Point °C  
 °F  
 Flash Point °C  
 °F  
 Evaporation  
 Foaming Sequence I, II, III  
 Copper Corrosion  
 Specific Gravity  
 USDA Authorization  
 Demulsibility

### ASTM Test Method

D-2422  
 D-445  
 D-445  
 D-2270  
 D-97  
 D-97  
 D-92  
 D-92  
 D-972  
 D-892  
 D-130  
 D-1298  
 H1 or H2  
 D-1401

### Nuvair™ 546

20  
 46  
 49.9  
 7.9  
 145  
 -54  
 -65  
 246  
 475  
 1.0%  
 Nil  
 1A  
 0.84  
 H-1  
 Excellent

## 17.4 LP Filtration



### CAUTION

Special attention needs to be given to the arrangement of the four LP Supply Air Filtration Elements and Bowls. Properly reinstall each Element and Bowl to the correct Housing. Improper sequence can cause damage to downstream components.

The use of Grade D or better supply air is critical to prevent the passing of any residual oil vapor into the Membrane System. Three stages of Hankison LP filtration are used to produce Grade D air:

- 1) Particle Removal to 1 micron
- 2) Coalescing & Water/Oil Vapor Removal to 0.01 micron
- 3) Oil Vapor Removal to 0.003 PPM

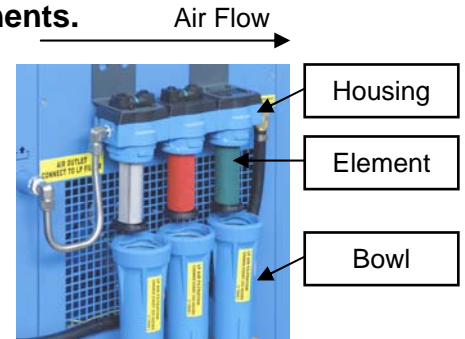

### Filtration Inspection

Open each Filter and inspect as follows:

1. Inspect Bowl for the presence of moisture. A high level of moisture build-up in the HF7 or HF5 Filter indicates improper operation of auto-drain floats. Any evidence of moisture in the HF1 Filter indicates the air is not cooling properly and moisture is not properly being removed. Excess moisture will prevent the final filter from operating properly.
2. Inspect Elements for any unusual degradation or wetness. Element degradation can indicate more serious problems. Contact Nuair for assistance,

### Changing Filtration Elements

Change Filter Elements every 100 hours. If the Nitrox System is operated in high humidity and/or high temperature, Filter Elements must be changed more often. See Appendix for details on Filter Element Life Factors. Visual DP indicators on the HF7 and HF5 filters assist with monitoring replacement intervals.

- 1) Push up on the Bowl, rotate CCW, and lower to remove.
- 2) Gently rotate Filter Element and pull down off mounting post.
- 3) Replace Element and reassemble in reverse order.

HF7-20 Particle Removal	HF5-20 Coalescing & Water/ Oil Vapor Removal	HF1-20 Oil Vapor Removal
-------------------------------	--	--------------------------------

HF7 & HF5  
Filters with Auto-  
Drain Floats &  
DP Indicators.

HF1 Filter with  
Manual Drain –  
Should not  
Contain Moisture

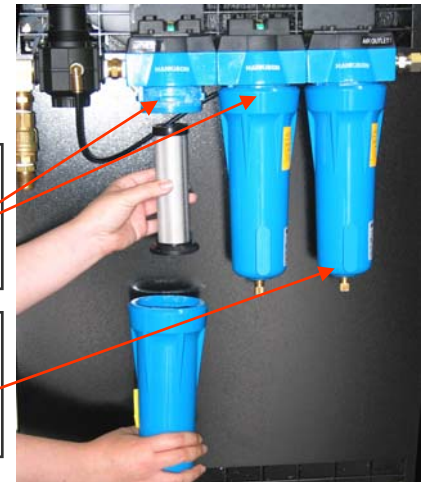

DP Indicator  
Changes from  
Green to Red as  
Filter Ages. Do  
Not Use When  
Red.



### NOTICE

The interior of the Filter Bowls can be cleaned with a diluted solution of Simple Green™ (a citrus based cleaner) and flushed thoroughly with clean water. This will assist to prolong the life of the element, bowl, and auto drain.

## 17.5 Spare Parts List

See Rotary Screw Compressor manual for LP Compressor parts list. Other Nitrox System components and related items are listed below.

<b>Nitrox System Components</b>	<b>Type</b>	<b>Part Number</b>
Rotary Screw Compressor Lubricant, Food Grade	Nuvair 546, 1 Gal (Other Sizes Available)	9409
LP Filtration Element	Hankison HF 7-20	E7-20
	Hankison HF 5-20	E5-20
	Hankison HF 1-20	E1-20
Heater Assembly	1200 Watt, 28" Length	H1200
Heater Thermostat Control	110V/220V	A419
Heater Pressure Switch		3100-052
Membrane	230 Series	NUV230
Air Intake Filter Element	LP280	16CP
Mixing Tube Assembly	1.5 inch diameter, specify length	
Oxygen Analyzer	Pro O2	9450
	Pro O2 Remote Panel Mount	9460
Oxygen Sensor	See Analyzer Owners Manual	
Compressor Hose Coupler	1-1/4"-1-1/2" to 1-1/4"-1-1/2"	PTC-150
	1-1/4"-1-1/2" to 1-1/2"	RDTC40X32
<b>Related Equipment Components</b>		
Air/Nitrox Quality Analysis Kit	Specify: (1) CGA Grade Required (2) Single Use or Program Use	
Air/Nitrox Compressor Lubricant		
Reciprocating Compressor, Food Grade	Nuvair 455, 1 Gal	9406
Reciprocating Compressor, Diester Based	Nuvair 751, 1 Gal (Other Sizes Available)	9403



## Appendix

### Supply and Breathing Air Specifications

All supply and breathing air must meet the following requirements of CGA G-7.1-1997. Supply air delivered to the Nitrox Membrane System must be purified to meet Grade D or E quality, and periodic air quality testing to assure compliance is recommended. All breathing air for diving produced by the downstream Compressor must be purified to meet Grade E quality, and periodic air quality testing to assure compliance is mandatory.

Item	Grade D	Grade E
◆ Oxygen	◆ 19.5-23.5%	◆ 20-22%
◆ Carbon Dioxide (maximum)	◆ 1000 PPM	◆ 1000 PPM
◆ Carbon Monoxide (maximum)	◆ 10 PPM	◆ 10 PPM
◆ Hydrocarbons (maximum)	◆ Not specified	◆ 25 PPM
◆ Water Vapor (maximum)	◆ Not specified	◆ Not specified
◆ Dew Point (maximum) (1)	◆ Not specified	◆ Not specified
◆ Oil & Particles (maximum) (2)	◆ 5 mg/m <sup>3</sup>	◆ 5 mg/m <sup>3</sup>
◆ Odor	◆ None	◆ None

Notes: (1) Dew Point of supply air must be >10°F (6°C) colder than coldest ambient air expected

(2) Supply air delivered to the Membrane System must contain <0.003 PPM Oil Vapor

All breathing Nitrox produced for diving must be purified to meet these same requirements, except for oxygen content. Nitrox oxygen content must measure within +/- 1% O<sub>2</sub> of the specified value of the mixture using a properly calibrated Oxygen Analyzer (i.e. Nitrox produced with a target content of 32% O<sub>2</sub> must measure in the range of 31-33% O<sub>2</sub>). Periodic air quality testing to assure compliance is mandatory.

### Filter Element Life Factors

Breathing air filter element life is typically rated by manufacturer based on an air temperature of 80°F at the filter inlet. Under normal operation this temperature is 12°F (5°C) warmer than the ambient air, resulting in an equivalent ambient temperature rating at 68°F (20°C).

To determine element life at a different ambient temperature, multiply the rated life by the life factor listed below:

Filter Temperature	Ambient Temperature	Filter Element Life Factor
53°F (12°C)	41°F (5°C)	2.6 x Life
62°F (17°C)	50°F (10°C)	1.8 x Life
71°F (23°C)	59°F (16°C)	1.35 x Life
<b>80°F (27°C)</b>	<b>68°F (20°C)</b>	<b>1 x Life</b>
89°F (32°C)	77°F (25°C)	0.8 x Life
96°F (36°C)	84°F (29°C)	0.55 x Life
105°F (41°C)	93°F (34°C)	0.45 x Life
114°F (46°C)	102°F (39°C)	0.35 x Life

Nuvair  
 2949 West 5<sup>th</sup> St.  
 Oxnard, CA 93030 USA  
 Ph: 1-805-815-4044  
 Fax: 1-805-815-4196

## Material Safety Data Sheet

Nuvair™ 546

EFFECTIVE DATE: 9/3/03

SUPERCEDES: 2/1/02

### I. PRODUCT IDENTIFICATION:

**Trade Name:** Nuvair™ 546

Chemical Name: Polyalphaolefin

Chemical Family: Synthetic Hydrocarbon

### II. COMPONENTS & HAZARD STATEMENT:

This product is non-hazardous. The product contains no known carcinogens. No special warning labels are required under OSHA CFR 1910.1200.

### III. PHYSICAL DATA:

Viscosity:	46 cSt. @ 40 C
Specific Gravity (Water = 1.0):	0.84
Boiling Point:	Not Determined
Vapor Pressure:	Negligible
Appearance & Odor:	Liquid, colorless, odorless
Solubility in Water:	Negligible
Other Data:	Non-Toxic USDA H-1 Approved

### IV. FIRE & EXPLOSION HAZARD DATA:

Flash Point:	475 F
Autoignition Temperature::	Not Determined
Flammability Limits:	Not Established
Extinguishing Media:	Dry Chemical; CO <sub>2</sub> Foam; Water Spray
Special Fire Fighting Procedure:	Burning may produce irritating/noxious fumes. Firefighters should use NIOSH/MNSA approved self-contained breathing apparatus. Use water to cool fire-exposed containers to prevent pressure build-up.

### V. REACTIVITY DATA:

Stability:	This product is stable and will not react with water.
Materials to Avoid:	Avoid strong oxidizers
Hazardous Decomposition Products:	Carbon monoxide, Carbon dioxide

### VI. HEALTH INFORMATION:

Eye Contact:	Flush eyes with water for 15 minutes. Call a physician if irritation develops.
Skin Contact:	Wash skin with soap and water.
Inhalation:	Remove to fresh air.
Ingestion:	First aid not normally required. If uncomfortable, call physician.

EFFECTIVE DATE: 9/3/03	SUPERCEDES: 2/1/02
PRODUCT: Nuvair™ 546	

VII. HEALTH HAZARD DATA:	
Exposure Limits:	Not applicable
Effects of Overexposure:	Low oral and dermal toxicity. Prolonged or repeated exposure may cause irritation, nausea, and vomiting.

VII. EMPLOYEE PROTECTION:	
For general personal hygiene, wash hands thoroughly after handling material. Avoid contact with skin and eyes.	
Chemical impervious gloves are recommended for prolonged exposure.	
Use in a well ventilated area	

VIII. STORAGE, SPILL & DISPOSAL PROCEDURES:	
Storage:	Store in clean, dry area.
Spills:	Use absorbent materials to soak up fluid.
Disposal:	Incinerate this product and all associated wastes in a licensed facility in accordance with Federal, state, and local regulations.

IX. HAZARD RATING INFORMATION:			
	NFPA	KEY	
Health:	1	4=Severe	0=Minimal
Flammability:	1	3=Serious	
Reactivity:	0	2=Moderate	B=Gloves,Goggles
Personal Protection:	B	1=Slight	

This information contained herein is based on the data available to us and is believed to be true and accurate. Nuvair makes no warranty, expressed or implied, regarding the accuracy of this data or the results to be obtained from the use thereof. Nuvair assumes no responsibility for injury from the use of this product.

For Additional Information:  
 Nuvair  
 2949 West 5<sup>th</sup> St.  
 Oxnard, CA 93030 USA  
 Ph: 1-805-815-4044  
 Fax: 1-805-815-4196  
 Website: [www.nuvair.com](http://www.nuvair.com)  
 E-mail: [info@nuvair.com](mailto:info@nuvair.com)

# Nuvair™ 455 Premium Synthetic Food Grade Air/Nitrox Compressor Lubricant

Effective Date: 7/8/2003

## I. Product Identification:

Trade Name: ..... Nuvair 455  
Chemical Name: ..... Polyalphaolefin  
Chemical Family: ..... Synthetic hydrocarbon mix

## II. Components & Hazard Statement:

**This product is non-hazardous.** The product contains no known carcinogens. No special warning labels are required under OSHA CFR 1910.1200. This product complies with FDA 21 CFR 178.3570 regarding lubricants for incidental food contact.

## III. Physical Data:

Viscosity: ..... 70 cst. @40°C  
Specific Gravity (Water = 1.0): ..... 0.83 – 0.85  
Boiling Point: ..... N.A.  
Vapor Pressure: ..... Negligible  
Appearance & Odor: ..... Clear – with little odor  
Solubility in Water: ..... Negligible

## IV. Fire & Explosion Hazard Data:

Flash point: ..... 490°F COC  
Autoignition Temperature: ..... Not Established  
Flammability Limits: ..... Not Established  
Extinguishing Media: ..... Dry Chemical; CO2 Foam; Water Spray  
Special Fire Fighting Procedure: ..... Burning may produce irritating/noxious fumes. Firefighters should use NIOSH/MNSA approved self-contained breathing apparatus. Use water to cool fire-exposed containers to prevent pressure build-up.

## V. Reactivity Data:

Stability: ..... This product is stable and will not react with water.  
Materials to Avoid: ..... Avoid strong oxidizers  
Hazardous Decomposition Products: ..... Carbon monoxide, Carbon dioxide

## VI. Health Information:

Eye Contact: ..... Flush eyes with water for 15 minutes. Call physician if irritation develops.  
Skin Contact: ..... Wash skin with soap and water.  
Inhalation: ..... Remove to fresh air.  
Ingestion: ..... First aid not normally required. If uncomfortable, call physician.

## VII. Health Hazard Data:

Exposure Limit: ..... Not Applicable  
Effects of Overexposure: ..... Low oral and dermal toxicity. Prolonged or repeated exposure may cause irritation, nausea, and vomiting.

## VIII. Employee Protection:

For general personal hygiene, wash hands thoroughly after handling material. Avoid contact with skin and eyes. Chemical impervious gloves are not required, but may be recommended for prolonged exposure. Use in a well ventilated area.

## IX. Storage, Spill, & Disposal Procedures:

Storage: ..... Store in clean, dry area.  
Spills: ..... Use absorbent materials to soak up fluid.  
Disposal: ..... Incinerate this product and all associated wastes in a licensed facility in accordance with Federal, state, and local regulations.

## X. Hazard Rating Information:

NFPA Health: ..... 1  
Flammability: ..... 1  
Reactivity: ..... 0  
Personal Protection: ..... B

This information contained herein is based on the data available to us and is believed to be true and accurate. Nuvair makes no warranty, expressed or implied, regarding the accuracy of this data or the results to be obtained from the use thereof. Nuvair assumes no responsibility for injury from the use of this product.



# Nuvair™ 751 Premium Synthetic Diester Based Air/Nitrox Compressor Lubricant

Effective Date: 2/1/2000

Supersedes: 9/1/1998

## I. Product Identification:

Trade Name: ..... Nuvair 751  
Chemical Name: ..... Diester/organic compound blend  
Chemical Family: ..... Ester

## II. Components & Hazard Statement:

**This product is non-hazardous.** The product contains no known carcinogens. No special warning labels are required under OSHA CFR 1910.1200, SARA TITLE 111 SECTION 313 (40 CFR PART 372): This product is not regulated under Section 313 and 40 CFR Part 372.

## III. Physical Data:

Viscosity: ..... 143 cst. @40°C  
Specific Gravity (Water = 1.0): ..... 0.96  
Boiling Point: ..... Not determined  
Vapor Pressure: ..... Negligible  
Appearance & Odor: ..... Straw color – bland odor  
Solubility in Water: ..... Negligible  
Other Data: ..... Non-toxic USDA H-2 approved

## IV. Fire & Explosion Hazard Data:

Flash point: ..... 520°F COC ASTM D-92  
Autoignition Temperature: ..... 765°F ASTM D-2155  
Flammability Limits: ..... Not Established  
Extinguishing Media: ..... Dry Chemical; CO2 Foam; Water Spray  
Special Fire Fighting Procedure: ..... Burning may produce irritating/noxious fumes. Firefighters should use NIOSH/MNSA approved self-contained breathing apparatus. Use water to cool fire-exposed containers to prevent pressure build-up.

## V. Reactivity Data:

Stability: ..... This product is stable and will not react with water.  
Materials to Avoid: ..... Avoid strong oxidizers  
Hazardous Decomposition Products: ..... Carbon monoxide, Carbon dioxide

## VI. Health Information:

Eye Contact: ..... Flush eyes with water for 15 minutes. Call physician if irritation develops.  
Skin Contact: ..... Wash skin with soap and water.  
Inhalation: ..... Remove to fresh air.  
Ingestion: ..... First aid not normally required. If uncomfortable, call physician.

## VII. Health Hazard Data:

Exposure Limit: ..... Not Applicable  
Effects of Overexposure: ..... Low oral and dermal toxicity. Prolonged or repeated exposure may cause irritation, nausea, and vomiting.

## VIII. Employee Protection:

For general personal hygiene, wash hands thoroughly after handling material. Avoid contact with skin and eyes. Chemical impervious gloves are not required, but may be recommended for prolonged exposure. Use in a well ventilated area.

## IX. Storage, Spill, & Disposal Procedures:

Storage: ..... Store in clean, dry area.  
Spills: ..... Use absorbent materials to soak up fluid.  
Disposal: ..... Incinerate this product and all associated wastes in a licensed facility in accordance with Federal, state, and local regulations.

## X. Hazard Rating Information:

NFPA Health: ..... 1  
Flammability: ..... 1  
Reactivity: ..... 0  
Personal Protection: ..... B

This information contained herein is based on the data available to us and is believed to be true and accurate. Nuvair makes no warranty, expressed or implied, regarding the accuracy of this data or the results to be obtained from the use thereof. Nuvair assumes no responsibility for injury from the use of this product.

## **OWNER'S WARRANTY RESPONSIBILITIES**

Failure of the owner to prevent equipment damage by complying with the procedures outlined below and in the Operation Manual will void the Nitrox System warranty.

### **Installation:**

- All set up requirements and procedures provided in the Nitrox System Operation Manual must be followed in their entirety including supply air cleanliness, Compressor preparation, and installation of the Nitrox System.
- Supply air to the Membrane must be properly filtered to CGA Grade D air quality or better to prevent damage to the Membrane. Air quality testing of the supply air should be performed periodically and documented to assure compliance.
- If there is any doubt regarding the suitability of a HP Compressor for compressing Nitrox, contact Nuvair or the Compressor manufacturer before you connect your Nitrox System.
- If an existing HP Compressor is to be used for compressing Nitrox, all traces of the old Lubricant must be removed and replaced with a Nitrox Compressor Lubricant approved by Nuvair.
- Electrical wiring and connections should be made by a qualified electrician in accordance with all national and local electrical codes.
- Do not change the temperature setting on the Heater Thermostat Control. Changes in temperature settings may cause Membrane damage.
- To prevent Compressor damage, only use the Compressor Intake Hose provided. If a longer hose is required, contact Nuvair for assistance.

### **Operation:**

- Do not use the Nitrox System to supply a HP Compressor with Nitrox mixtures containing more than 40% oxygen. Compressing higher concentrations of oxygen may cause severe Compressor damage.
- Do not pump Nitrox mixtures at pressures above the compressor manufacturer's rating, and never above 3600 P.S.I. Compressing Nitrox at higher pressures may cause severe HP Compressor damage.
- To prevent Membrane damage, drain all low pressure filter and volume tank condensate on a daily basis.

### **Maintenance:**

- Change low pressure filter elements on a schedule determined by filter capacity and ambient temperature and humidity. Contact Nuvair if you need assistance establishing a schedule for your equipment and location.
- Replace Membrane System Air Intake Filter on a regular basis to prevent flow obstruction.
- Keep all nuts, bolts, fittings, connectors, and clamps tight.
- Keep a service record book showing that regular maintenance work has been carried out. If a warranty claim becomes necessary, it will aid in demonstrating that damage has not been caused by insufficient maintenance. Proof of maintenance may be required prior to determining the validity of a warranty request.

## **NUVAIR NITROX SYSTEM WARRANTY**

NUVAIR extends a limited warranty, which warrants the Nitrox System to be free from defects in materials and workmanship under normal use and service for a limited period. The specific Membrane Component of the Nitrox System is warranted according to the pro-rated terms as set forth below. All other Original Equipment Manufacturer (OEM) components used in the system are warranted only to the extent of the OEM's warranty to NUVAIR. NUVAIR makes no warranty with respect to these OEM components, and only warrants the workmanship that NUVAIR has employed in the installation or use of any OEM component. This warranty is not transferable.

NUVAIR will, at its discretion and according to the terms as set forth within, replace or repair any materials which fail under normal use and service and do not exhibit any signs of improper maintenance, misuse, accident, alteration, weather damage, tampering, or use for any other than the intended purpose. Determination of failure is the responsibility of NUVAIR, which will work together with the customer to adequately address warranty issues. When any materials are repaired or replaced during the warranty period, they are warranted only for the remainder of the original warranty period. This warranty shall be void and NUVAIR shall have no responsibility to repair or replace damaged materials resulting directly or indirectly from the use of repair or replacement parts not approved by NUVAIR.

### **Pro-Rated Terms:**

NUVAIR warrants the Membrane Component of the Nitrox System to be free from defects in material and workmanship for a period of thirty-six (36) months from date of installation or forty-two (42) months from date of shipment by NUVAIR, whichever may occur first. The warranty covers parts only and is prorated as follows:

- First Year Repair or replacement free of charge
- Second Year Warranty allowance of 70% of the current Membrane Component list price
- Third Year Warranty allowance of 40% of the current Membrane Component list price

A warranty registration card, supplied with system documentation, must be filled out and submitted to NUVAIR for the warranty to be in full effect. If the warranty registration card is not received within thirty (30) days of installation, the thirty-six (36) month warranty will begin with the date of shipment from NUVAIR.

### **Maintenance Items:**

Any materials which are consumed, or otherwise rendered not warrantable due to processes applied to them, are considered expendable and are not covered under the terms of this policy. This includes maintenance and consumable items listed as part of a suggested maintenance program included with system documentation.

### **Return Policy:**

Application for warranty service can be made by contacting NUVAIR during regular business hours and requesting a Return Material Authorization number. Materials that are found to be defective must be shipped, freight pre-paid, to the NUVAIR office in Oxnard, California. Upon inspection and determination of failure, NUVAIR shall exercise its options under the terms of this policy. Warranty serviced materials will be returned to the customer via NUVAIR's preferred shipping method, at NUVAIR's expense. Any expedited return shipping arrangements to be made at customer's expense must be specified in advance.

### **Limitation of Warranty and Liability:**

Repair, replacement or refund in the manner and within the time provided shall constitute NUVAIR'S sole liability and the Purchaser's exclusive remedy resulting from any nonconformity or defect. NUVAIR shall not in any event be liable for any damages, whether based on contract, warranty, negligence, strict liability or otherwise, including without limitation any consequential, incidental or special damages, arising with respect to the equipment or its failure to operate, even if NUVAIR has been advised of the possibility thereof. NUVAIR makes no other warranty or representation of any kind, except that of title, and all other warranties, express or implied, including warranties of merchantability and fitness for a particular purpose, are hereby expressly disclaimed. No salesman or other representative of NUVAIR has authority to make any warranties.



*Operation Manual*

**Pro O<sub>2</sub><sup>TM</sup>**  
**Pro O<sub>2</sub> Remote<sup>TM</sup>**

Oxygen Analyzers

If you have any questions on this equipment please contact Technical Support at:

Nuvair  
2949 West 5<sup>th</sup> St.  
Oxnard, CA 93030

Phone: 805-815-4044  
FAX: 805-815-4196  
Email: [info@nuvair.com](mailto:info@nuvair.com)

Hours: Monday through Friday  
8:00 AM to 5:00 PM PST USA



## WARNING

**This Operation Manual contains important safety information and should always be available to those personnel operating this equipment. Read, understand, and retain all instructions before operating this equipment to prevent injury or equipment damage.**

Every effort was made to ensure the accuracy of the information contained within this manual; however, we retain the right to modify its contents without notice. If you have problems or questions after reading the manual, stop and call for information.

## Table of Contents

18.0	Introduction .....	4
19.0	System Description .....	5
19.1	Controls .....	6
19.2	Display .....	6
19.3	Oxygen Sensor .....	6
19.4	Battery .....	7
19.5	Flow Adapter Cap (Pro O <sub>2</sub> <sup>TM</sup> ) .....	7
19.6	Flow Diverter (Pro O <sub>2</sub> Remote <sup>TM</sup> ) .....	8
20.0	Calibration .....	9
20.1	Calibration Methods .....	9
20.2	Calibration in Air .....	10
21.0	Operation .....	12
21.1	Pro O <sub>2</sub> <sup>TM</sup> .....	12
21.2	Pro O <sub>2</sub> Remote <sup>TM</sup> .....	14
22.0	Maintenance .....	15
22.1	Analyzer Care .....	15
22.2	Battery Replacement .....	15
22.3	Oxygen Sensor Replacement .....	16
23.0	Spares and Accessories .....	19
23.1	Oxygen Sensor .....	19
23.2	Flow Restrictors and Regulators .....	19
23.3	Tee Adapter .....	19
24.0	Troubleshooting .....	20
Appendix	.....	21
	Calibration Correction Values for Temperature and Humidity .....	21
	Analyzer Specifications .....	22
	Warranty .....	23

## 1.0 Introduction

This manual will assist you in the proper set-up, operation and maintenance of the Pro O<sub>2</sub><sup>™</sup> and Pro O<sub>2</sub> Remote<sup>™</sup> Oxygen Analyzers. Be sure to read the entire manual.

**Throughout this manual we will use certain words to call your attention to conditions, practices or techniques that may directly affect your safety. Pay particular attention to information introduced by the following signal words:**



Indicates an imminently hazardous situation, which if not avoided, will result in serious personal injury or death.



Indicates a potentially hazardous situation, which if not avoided, could result in serious personal injury or death.



Indicates a potentially hazardous situation, which if not avoided, may result in minor or moderate injury. It may also be used to alert against unsafe practices.



Notifies people of installation, operation or maintenance information which is important but not hazard-related.

## 2.0 System Description

The Pro O<sub>2</sub><sup>TM</sup> and Pro O<sub>2</sub> Remote<sup>TM</sup> Oxygen Analyzers (“the Analyzer”) measure oxygen (O<sub>2</sub>) levels in gases in the range of 0.1 - 100.0% O<sub>2</sub>. The choice of Analyzer depends on the application:

- Pro O<sub>2</sub><sup>TM</sup> – where pressurized gas must be analyzed and the pressure and flow of the sample flow can be regulated
- Pro O<sub>2</sub> Remote<sup>TM</sup> - where non-pressurized gas must be analyzed or for pressurized gas applications where the Analyzer must be located remote to the sensor

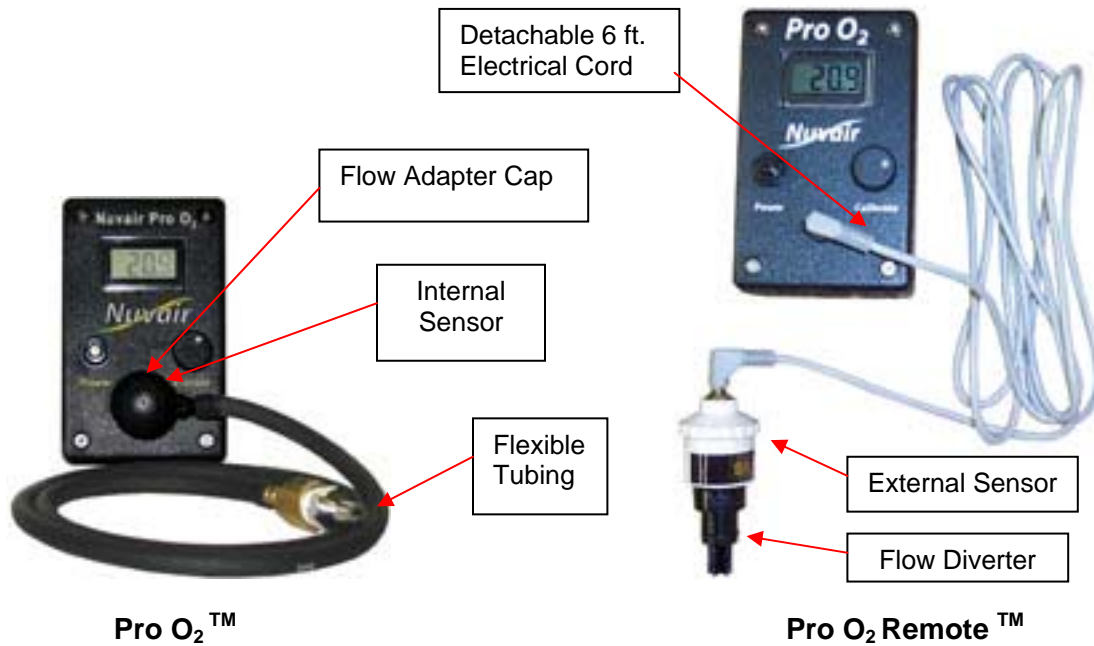

The Analyzer is a water and impact resistant unit compatible with outdoor and marine environments. Pressurized gases must be regulated to one atmosphere absolute (0 P.S.I.) prior to analyzing.

When used in breathing gas applications, redundant Analyzers must be used for verification. In diving, for example, one Analyzer must be used to monitor oxygen during breathing gas production and a second independent Analyzer must be used to verify the oxygen content of the breathing gas prior to diver use.



### WARNING

**When using the Analyzer for diving applications with mixed gases other than air, you must first obtain proper instruction from a certified diving instructor with a nationally recognized training agency qualified in mixed gas diving. Improper use of this analyzer may result in incorrect gas analysis which can lead to serious personal injury or death.**





## WARNING

Although the Analyzer is a rugged instrument, careless handling or abuse may result in damage to the Analyzer resulting in inaccurate gas analysis. Inaccurate gas analysis can lead to serious personal injury or death.



## WARNING

Breathing gas must always be analyzed by two separate Analyzers, with one used for production and one used for analysis after production. Never depend on a single Analyzer during both gas production and delivery. If the Analyzer readings do not agree, both units must be recalibrated. Inaccurate gas analysis can lead to serious personal injury or death.

### 2.1. Controls



### 2.2. Display



### 2.3. Oxygen Sensor

The Analyzer uses an electrochemical O<sub>2</sub> Sensor to measure O<sub>2</sub> content in gases. The Sensor is disposable and user-replaceable, with a life expectancy of up to 36 months depending on usage. The Sensor is designed for use at one atmosphere absolute (0 P.S.I.) pressure. The gas mixture to be analyzed must be regulated accordingly, and any potential for pressure or vacuum must be avoided.

To extend sensor life, the Analyzer is supplied with the Sensor in a sealed condition. When first received, please verify that sealing device is intact. If the sealing device is torn or missing, contact your supplier for assistance. The sealing device must be removed prior to initial use and is not necessary to reuse.

## Pro O<sub>2</sub>™

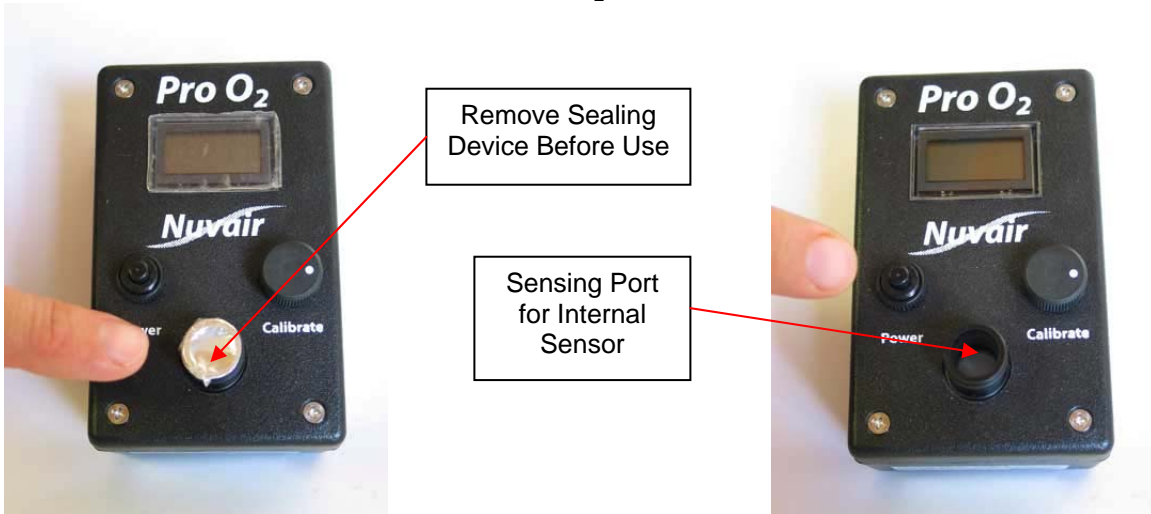

## Pro O<sub>2</sub> Remote™



### 2.4. Battery

Power is provided by a standard alkaline 9-volt battery. It is located inside the Analyzer and is user-replaceable.

### 2.5. Flow Adapter Cap (Pro O<sub>2</sub>™)

The Flow Adapter Cap with flexible tubing and flow orifice attaches to the Pro O<sub>2</sub>™ Sensor port and is sealed by an o-ring. It can be used to direct the gas sample flow to the Sensor via one of two methods:

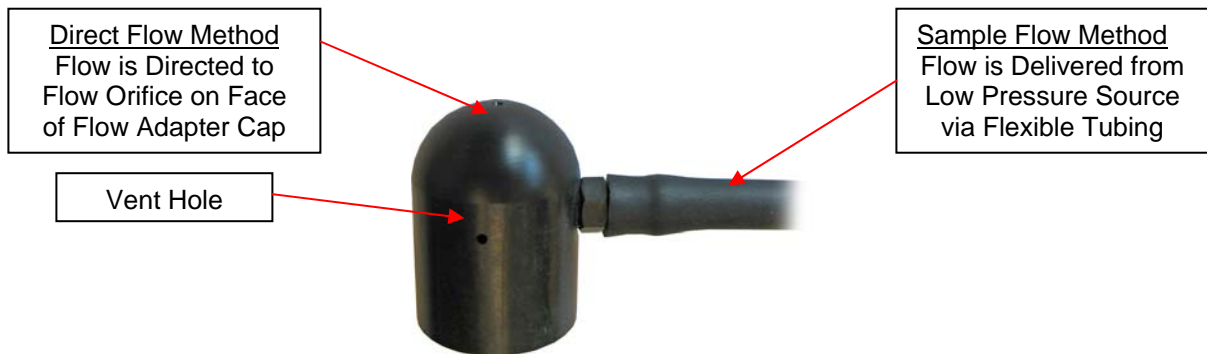

## 2.6. Flow Diverter (Pro O<sub>2</sub> Remote™)

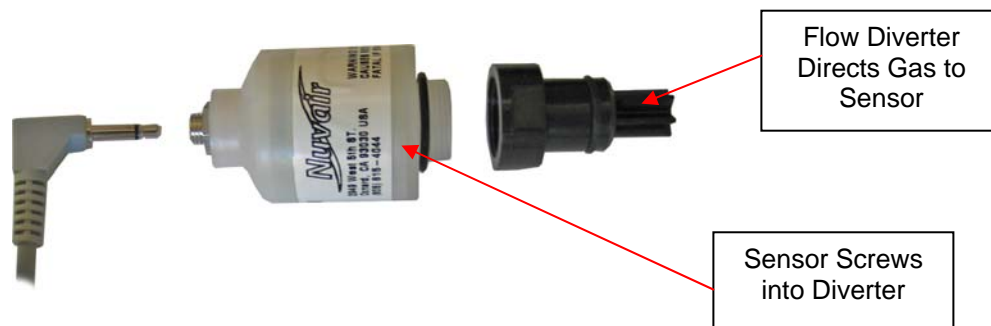

The Flow Diverter is installed to the user's non-pressurized device to direct gas flow to the Sensor:

- Slip Fit Method – Install optional Tee Adapter (see Spares and Accessories section) in-line with gas flow path. Insert Flow Diverter with o-ring into small bore of Adapter.
- Press Fit Method – Remove the Flow Diverter o-ring and press fit the Diverter into a 9/16 inch diameter cylindrical bore in gas flow path.

### 3.0 Calibration



#### WARNING

**Oxygen Analyzers must be calibrated before each use. Improper calibration may result in the use of incorrect breathing gas mixtures, which may cause serious injury or death to the person using the gas mixture.**



#### WARNING

**Calibration or use of the Analyzer with a low battery may result in inaccurate readings. Inaccurate gas analysis can lead to serious personal injury or death.**



#### NOTICE

**If the Analyzer has been subjected to a recent change in ambient temperature, allow it to stabilize for one hour before calibration.**



#### WARNING

**When Analyzer calibration is performed at different atmospheric conditions than the gas being measured, a calibration correction value may be required. Improper calibration may result in the use of incorrect breathing gas mixtures, which may cause serious injury or death to the person using the gas mixture.**

#### 3.1. Calibration Methods

Calibration should always be performed at the same temperature and humidity conditions as the gas being measured. This is not always possible, for example, in a tropical environment where dry breathing gas from a high-pressure Scuba cylinder will be measured after Analyzer calibration has been performed in the warm, humid ambient air. Under these conditions a calibration correction value may be required, as detailed in the Appendix, or dry air must be used for calibration.



#### WARNING

**Obtain proper training before attempting special calibration procedures. Improper calibration may result in the use of incorrect breathing gas mixtures, which may cause serious injury or death to the person using the gas mixture.**

Calibration in air at sea level is suitable for many applications; however, the closer the oxygen content of the calibration gas is to the gas being tested, the more accurate the measurement results. The following special applications require methods and training beyond the scope of this manual:

- Analysis of gases containing greater than 50% oxygen requiring calibration with pure oxygen or certified calibration gas
- Analysis of gases at altitudes above sea level requiring correction for reduced atmospheric pressure

### 3.2. Calibration in Air

The following pictures illustrate the steps required to calibrate the Pro O<sub>2</sub>™ Analyzer.

#### Pro O<sub>2</sub>™

Turn Analyzer On

Monitor Display for Low Battery Warning



Step 1

Remove Flow Adapter Cap

Expose Sensor Port to Still Air Until Display Stabilizes



Step 2

Adjust Calibrate Knob Until Display Reads 20.9%



Step 3

Replace Flow Adapter Cap

Do Not Disturb Calibrate Knob



Step 4

The following pictures illustrate the steps required to calibrate the Pro O<sub>2</sub> Remote™ Analyzer.

### Pro O<sub>2</sub> Remote™

Turn Analyzer On

Monitor Display For Low Battery Warning



Unscrew Sensor From Flow Diverter

Expose Sensor Port to Still Air Until Display Stabilizes

#### Step 2

Adjust Calibrate Knob Until Display Reads 20.9% O<sub>2</sub>



#### Step 3

Verify Electrical Cord is Firmly Attached at Both Ends

Reinstall Sensor to Diverter



#### Step 4

## 4.0 Operation

Prior to each Analyzer use:

- 1) Verify that Sensor sealing device is removed
- 2) Turn unit on and monitor Display for low battery warning
- 3) Calibrate Analyzer as required.



### WARNING

**Never expose the Oxygen Sensor to pressure or you may cause damage and/or false readings. Damaged Sensors will not provide accurate gas analysis. Inaccurate gas analysis can lead to serious personal injury or death.**

#### 4.1. Pro O<sub>2</sub>™

The Pro O<sub>2</sub>™ can be used to analyze a regulated gas sample flow, the contents of a gas cylinder, or the flow from a regulator. The flow rate of gas must equal 1 – 5 L/min. To produce this flow, a Flow Restrictor and Regulator may be required. See Spares and Accessories section.



### WARNING

**Gas, even under moderate pressures, can cause extreme bodily harm. Never allow any gas stream to be directed at any part of your body.**

#### Sample Flow Method

Attach Flexible Tubing to Gas Sample Flow of 1-5 L/min



Step 1

Verify that Gas is Flowing Out Holes in Flow Adapter Cap



Step 2

Allow 15 Seconds for Display Reading to Stabilize

Record Reading while Gas is Flowing



Step 3

When analyzing Scuba Cylinder gases, it is convenient to obtain the sample gas directly from the Buoyancy Compensator (BC) inflator hose attached to the Regulator first stage.

A special Flow Restrictor is attached to the inflator hose quick-disconnect (QD) fitting. The fitting on the other end of the Restrictor is then inserted into the tubing supplied with the Analyzer. A variety of Flow Restrictors are available to fit different types of inflator hose QD fittings. See Spares and Accessories section.

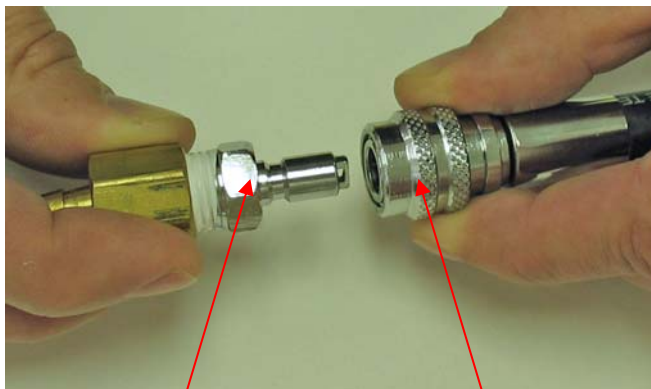

Flow Restrictor

BC Inflator Hose QD Fitting

**Direct Flow Method – Gas Cylinder**

Slowly Open Cylinder Valve until Slight Hiss of Gas is Heard



Hold Flow Adapter Cap Flow Orifice up to Gas Flow

Verify that Gas is Flowing Out Tubing



**Step 1**

Allow 15 Seconds for Display Reading to Stabilize

Record Reading While Gas is Flowing



Close Cylinder Valve & Remove Analyzer

Verify that Gas Continues to Flow from Valve. If Not, Repeat Procedure



**Step 3**



## Direct Flow Method – Scuba Regulator

- Attach Scuba Regulator to Cylinder Valve
- Open Cylinder Valve



- Lightly Press Regulator Purge Button to Get Very Low Flow of Gas
- Hold Flow Adapter Cap Flow Orifice Up to Gas Flow



**Step 1**

- Allow 15 Seconds for Display Reading to Stabilize
- Record Reading while Gas is Flowing



**Step 3**

### 4.2. Pro O<sub>2</sub> Remote™

The Pro O<sub>2</sub> Remote™ is used where non-pressurized gas must be analyzed or for pressurized gas applications where the Analyzer must be located remote to the sensor:

- Begin Flow of Gas Stream Past Sensor

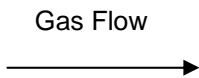

- Allow 15 Seconds for Display Reading to Stabilize
- Record Reading while Gas is Flowing



**Step 2**

## 5.0 Maintenance

### 5.1. Analyzer Care

- Do not clean Analyzer with anything other than a damp soft cloth.
- Do not immerse Analyzer in liquid, leave unprotected outside, or store in a wet environment.
- Protect Analyzer from excessive shock and impact.
- Protect Analyzer from excessive exposure to sunlight and extreme temperatures.

### 5.2. Battery Replacement



**NOTICE**

**Be sure to dispose of spent, leaking, or damaged Batteries properly, according to local regulations.**

The following pictures illustrate the steps required to replace the battery in the Analyzer.

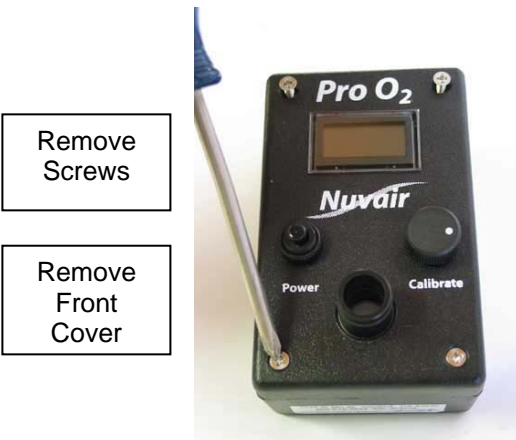

Remove  
Screws

Remove  
Front  
Cover

**Step 1**

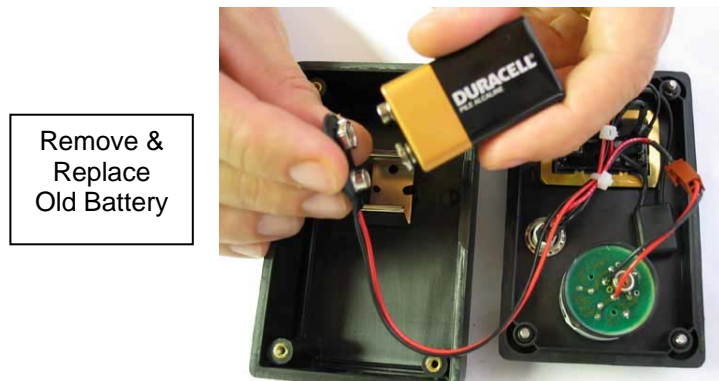

Remove &  
Replace  
Old Battery

**Step 2**



Replace  
Front Cover  
- Do Not  
Pinch Wires

Reinstall  
Screws

**Step 3**

Turn Analyzer  
On

Perform Air  
Calibration



**Step 4**

### 5.3. Oxygen Sensor Replacement



**CAUTION**

Be sure to dispose of spent, leaking, or damaged Oxygen Sensors properly, according to local regulations.



**DANGER**

Do not swallow (ingest) either the electrolyte from the Oxygen Sensor or the Sensor itself. The Potassium Hydroxide chemical contained in the Sensor can cause severe injury or death. If electrolyte or the Sensor is swallowed, seek medical attention immediately.



**WARNING**

If after handling the Oxygen Analyzer or Sensor, you find that your fingers or other parts of your body feel “slippery” or the skin or eyes sting, immediately flush affected area with clean, fresh water for at least 15 minutes. The stinging or slippery sensation is an indication of a leaking Sensor. The Potassium Hydroxide chemical contained in the Sensor can cause severe injury or death. Seek immediate medical attention if eye contact is made or skin stinging persists.

#### Handling Sensors

Replacement Sensors are supplied in sealed bags. Normally Sensors do not present a health hazard. Before opening the bag, check that the electrolyte has not leaked. However, if electrolyte leakage has occurred, do not open bag. Dispose of Sensor properly or return for replacement.

If electrolyte leakage occurs while the Sensor is in service, use rubber gloves and chemical splash goggles for handling. Rinse contaminated surfaces thoroughly with water.

#### Electrolyte First Aid Procedures

- Ingestion - Drink a large volume of fresh water. Do not induce vomiting. Get immediate medical attention.
- Eye Contact - Flush eyes with clean, fresh water for at least 15 minutes and get medical help immediately.
- Skin Contact - Flush the affected area with clean, fresh water for at least 15 minutes and removed contaminated clothing. If stinging persists get medical attention.

The following pictures illustrate the steps required to replace the Sensor in the Pro O<sub>2</sub>™.

### Pro O<sub>2</sub>™

Remove Flow Adapter Cap



Step 1

Remove Screws

Remove Front Cover



Step 2

Disconnect Electrical Connector

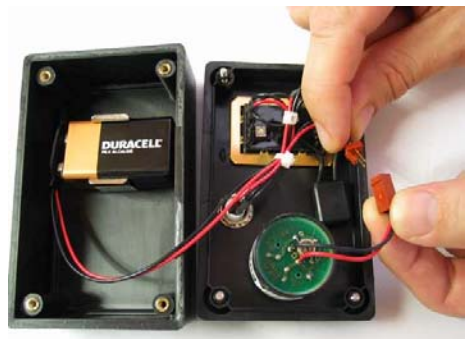

Step 3

Remove Old Sensor from Cover by Unscrewing CCW

Replace with New Sensor



Step 4

Reconnect Electrical Connector

Note: Reversing Polarity Will Cause Display to Read Negative

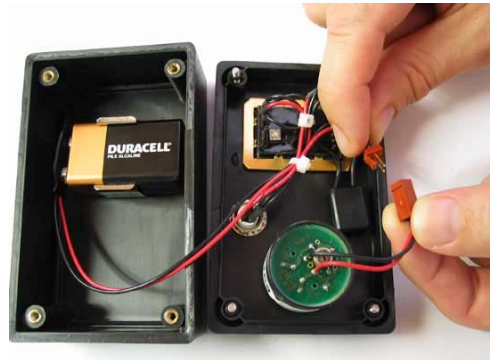

Step 5

Replace Front Cover - Do Not Pinch Wires

Reinstall Screws



Step 6

Turn Analyzer On

Perform Air Calibration



Step 7

The following pictures illustrate the steps required to replace the Sensor in the Pro O<sub>2</sub> Remote.

### Pro O<sub>2</sub> Remote™

Disconnect  
Electrical  
Cord from  
Sensor



**Step 1**

Remove and  
Replace Old  
Sensor



**Step 2**

Reconnect  
Electrical  
Cord to  
Sensor



**Step 3**

Turn  
Analyzer On

Perform Air  
Calibration



**Step 4**

## 6.0 Spares and Accessories

### 6.1. Oxygen Sensors

Order the replacement Sensor closest in appearance to your existing Sensor.



Part No. D-15



Part No. R-33D



Part No. R-17DNUV

### 6.2. Flow Restrictors and Regulators (Pro O<sub>2</sub>™)

A variety of Flow Restrictors and Pressure Regulators for the Sample Flow Method are available from Nuvair, all calibrated to produce a flow rate of 1 – 5 L/min with a Regulator output of 100 – 160 P.S.I.

Universal Flow Restrictors are used for most applications and are typically provided complete with Regulator.

When analyzing Scuba Cylinder gases, special Flow Restrictors can be used to obtain the sample gas directly from the BC inflator hose. A variety of BC Flow Restrictors are available to fit the different types of inflator hose QD fittings used.

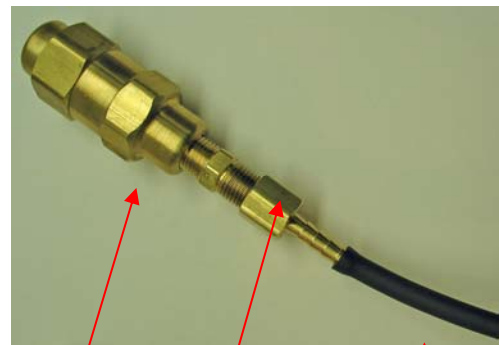

Pressure Reducing Regulator

Universal Flow Restrictor

LP Hose to Analyzer



Standard Flow Restrictor  
Part No. AA04



Mares™ Flow Restrictor  
Part No. A167



ScubaPro™ Flow Restrictor  
Part No. AA05

### 6.3. Tee Adapter (Pro O<sub>2</sub> Remote™)

When using the Pro O<sub>2</sub> Remote™ to analyze in-line gas flow, the Tee Adapter is used to install the Sensor and Flow Diverter in the gas path.

Tee Adaptor  
Part No. 6024

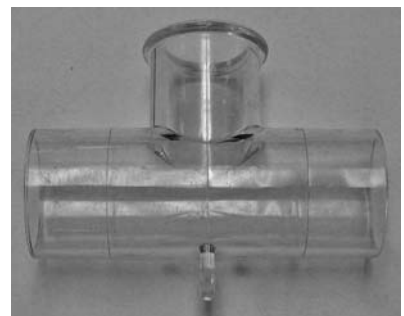

## 7.0 Troubleshooting

SYMPTOM	REASON	SOLUTION
Battery symbol	Low Battery	Change the battery
No display	Switched off Bad connection	Switch on Check display connection Check battery connection
Zero reading	Sensor disconnected Sensor expired	Check connection Change sensor
Reading erratic	Pressure on sensor Radio transmission Sensor old or faulty Condensation on sensor.	Check flow Move unit away Change sensor Dry in air
Reading does not change when calibration knob is turned	Faulty connections Sensor failure	Check connections Change sensor
Display segments missing	Display faulty	Return to dealer
Will not calibrate	Sensor faulty Sensor not in air High altitude	Change sensor Check flow adapter Use altitude calibration procedure
Reading drifts	Rapid temperature change	Stabilize temperature & recalibrate

## Appendix

### Calibration Correction Values for Temperature and Humidity

Oxygen Analyzer calibration should always be performed at the same temperature and humidity conditions as the gas being measured. Where this is not possible, a calibration correction value may be required. A common example is a tropical environment where dry breathing gas from a high-pressure Scuba cylinder will be measured after Analyzer calibration has been performed in the warm, humid ambient air.

To determine if a calibration correction value is required, you must first know the temperature and relative humidity of the air in which calibration will be performed. Using the chart below, find the atmospheric oxygen percent value corresponding to these values. If the oxygen percent value falls in the shaded portion of the chart, calibrate the Analyzer to the corrected chart value.

### OXYGEN COMPENSATION CHART FOR MOISTURE IN THE ATMOSPHERE

ATMOSPHERE OXYGEN PERCENT IN RELATION TO TEMPERATURE AND RELATIVE HUMIDITY										
TEMPERATURE (°F) -->	32	40	50	60	70	80	90	100	110	120
TEMPERATURE (°C) -->	0	4	10	16	21	27	32	38	43	49
RELATIVE HUMIDITY (%)	ATMOSPHERIC OXYGEN PERCENT (% O <sub>2</sub> )									
10	20.9	20.9	20.9	20.9	20.8	20.8	20.8	20.8	20.7	20.7
20	20.9	20.9	20.8	20.8	20.8	20.8	20.7	20.6	20.5	20.4
30	20.9	20.8	20.8	20.8	20.7	20.7	20.6	20.5	20.4	20.2
40	20.8	20.8	20.8	20.7	20.7	20.6	20.5	20.4	20.2	19.9
50	20.8	20.8	20.8	20.7	20.6	20.5	20.4	20.2	20.0	19.7
60	20.8	20.8	20.7	20.7	20.6	20.5	20.3	20.1	19.8	19.5
70	20.8	20.8	20.7	20.6	20.5	20.4	20.2	19.9	19.6	19.2
80	20.8	20.8	20.7	20.6	20.5	20.3	20.1	19.8	19.5	19.0
90	20.8	20.7	20.7	20.6	20.4	20.3	20.0	19.7	19.3	18.7
100	20.8	20.7	20.6	20.5	20.4	20.2	19.9	19.5	19.1	18.5
H <sub>2</sub> O at 100% RH	0.6	0.8	1.2	1.8	2.5	3.4	4.7	6.5	8.6	11.5

If the Temperature and Relative Humidity axis meet in the shaded part of the chart, calibrate to the chart O<sub>2</sub> level or with dry air to maintain 0.5% O<sub>2</sub> accuracy in NITROX.

To use the correction value, follow the standard Calibration in Air procedure with the following exceptions:

- Make sure Oxygen Sensor port is exposed to the ambient temperature and humidity corresponding to the correction value.
- Adjust the Calibrate Knob to achieve a Display reading equal to the correction value.
- Once you have calibrated the Analyzer for temperature and humidity using the, your readings for gas analysis should be correct with no further adjustment.
- Re-calibrate Analyzer for any changes in temperature or humidity of the ambient environment or the gas being analyzed.

Note that the calibration correction value is never used when the temperature and humidity conditions of the gas being measured are the same as the conditions during calibration.



## Analyzer Specifications

Range:	0.1-100.0% Oxygen (0-1 ATA PPO <sub>2</sub> )
Display Accuracy:	+/- 0.1%
Sensor Type:	Electrochemical
Expected Sensor Life, Room Air:	36 Months
Power:	9V Alkaline Battery
Response Time:	Less Than 6 Seconds to 90% of Final Value
Operating Temperature:	32-104°F (0-40°C)
Storage Temperature:	32-122°F (0-50°C)
Pressure:	Sensitive to Partial Pressure
Humidity:	0-99% RH (Non-Condensing)
Warranty:	36 Months Pro-Rated

Note: All specifications are at ambient / sea level, 25°C

## NUVAIR Pro O<sub>2</sub>™ and Pro O<sub>2</sub> Remote™ Warranty

NUVAIR extends a limited warranty, which warrants the Pro O<sub>2</sub>™ and Pro O<sub>2</sub> Remote™ (Pro O<sub>2</sub>) to be free from defects in materials and workmanship under normal use and service for a limited period. The Pro O<sub>2</sub> is warranted according to the pro-rated terms as set forth below. This warranty is not transferable.

NUVAIR will, at its discretion and according to the terms as set forth within, replace or repair any materials which fail under normal use and service and do not exhibit any signs of improper maintenance, misuse, accident, alteration, weather damage, tampering, or use for any other than the intended purpose. Determination of failure is the responsibility of NUVAIR, which will work together with the customer to adequately address warranty issues. When any materials are repaired or replaced during the warranty period, they are warranted only for the remainder of the original warranty period. This warranty shall be void and NUVAIR shall have no responsibility to repair or replace damaged materials resulting directly or indirectly from the use of repair or replacement parts not approved by NUVAIR.

### Pro-Rated Terms:

NUVAIR warrants the Pro O<sub>2</sub> to be free from defects in material and workmanship for a period of thirty-six (36) months from date of purchase. The warranty covers parts and labor and is prorated as follows:

- 0 – 12 Months            Repair or replacement free of charge
- 13 – 18 Months        Warranty allowance of 75% of purchase price
- 19 – 24 Months        Warranty allowance of 50% of purchase price
- 25 – 36 Months        Warranty allowance of 25% of purchase price

A warranty registration card, supplied with system documentation, must be filled out and submitted to NUVAIR for the warranty to be registered. If the warranty registration card is not received within ten (10) days of purchase, the warranty will begin with the date of manufacture by NUVAIR.

### Maintenance Items:

Any materials which are consumed, or otherwise rendered not warrantable due to processes applied to them, are considered expendable and are not covered under the terms of this policy. This includes the 9-volt battery used in the Pro O<sub>2</sub>.

### Return Policy:

Application for warranty service can be made by contacting NUVAIR during regular business hours and requesting a Return Material Authorization number. Materials that are found to be defective must be shipped, freight pre-paid, to the NUVAIR office in Oxnard, California. Upon inspection and determination of failure, NUVAIR shall exercise its options under the terms of this policy. Warranty serviced materials will be returned to the customer via NUVAIR's preferred shipping method, at NUVAIR's expense. Any expedited return shipping arrangements to be made at customer's expense must be specified in advance.

### Limitation of Warranty and Liability:

Repair, replacement or refund in the manner and within the time provided shall constitute NUVAIR'S sole liability and the Purchaser's exclusive remedy resulting from any nonconformity or defect. NUVAIR shall not in any event be liable for any damages, whether based on contract, warranty, negligence, strict liability or otherwise, including without limitation any consequential, incidental or special damages, arising with respect to the equipment or its failure to operate, even if NUVAIR has been advised of the possibility thereof. NUVAIR makes no other warranty or representation of any kind, except that of title, and all other warranties, express or implied, including warranties of merchantability and fitness for a particular purpose, are hereby expressly disclaimed. No salesman or other representative of NUVAIR has authority to make any warranties.

**ROTAIR** S.p.A.

***Operating manual***  
***Of the rotary compressor***  
***with electronic card***

**RVK**

[ ]	
[ ]	RVK 10
[ ]	RVK 15
[ ]	RVK 20

## -- 1) RVK COMPRESSOR INDEX --

1. Identification data
2. Technical data
3. The purpose of the manual and who it is to be consulted by
4. Operational Limits
5. Precautions
6. Technical description
7. Control instrument and devices
8. Electronic card description
9. Machine installation
10. Machine use instruction
11. Safety devices
12. Maintenance program
13. Checking and maintenance

### **CAUTION**

**This manual explains the proper operational procedures for using and maintaining the Coltri/Nuvair Rotair compressor for the delivery of nitrox (oxygen enriched air) and compressed air. Failure on the part of the operator to follow recommended procedures and proper maintenance voids all warranties and relieves the manufacturer of any liability for damage to equipment or injuries or death of operators.**

-- 1) IDENTIFICATION DATA --

Here follows details of the information printed on the machine identification plate situated at the front of the machine.

MODEL: **RVK**

REGISTRATION NO.:

MASS (Kg):

AIR DELIVERY (litres per minute) \* :

WORKING PRESSURE (bar):

YEAR OF CONSTRUCTION:

ACOUSTIC POWER dB(A) \*\* : < 100

(\*)Measured in accordance with ISO 1217 standards ( $\pm 5\%$ ).

(\*\*)Measured in accordance with directive CEE 84/533, technical adaptation 85/406/CEE.



**CAUTION:**

***The use of non-original ROTAIR S.P.A. spares will result in the immediate cancellation of the guarantee.***

*On requesting assistance or ordering of parts always cite the model number and registration number above.*

**-- 2) TECHNICAL DATA --**

Model	Motor rated power	Motor rated power	Air output	Pressure	Type of belts
	HP	Kw	ISO 1217 lt/1'		
<b>RVK 8/8</b>	7,5	5,5	870	8	Poly- V sez.K
<b>RVK 8/10</b>	7,5	5,5	780	10	Poly- V sez.K
<b>RVK 10/8</b>	10	7,5	1190	8	Poly- V sez.K
<b>RVK 10/10</b>	10	7,5	1070	10	Poly- V sez.K
<b>RVK 10/13</b>	10	7,5	850	13	Poly- V sez.K
<b>RVK 15/8</b>	15	11	1780	8	Poly- V sez.K
<b>RVK 15/10</b>	15	11	1450	10	Poly- V sez.K
<b>RVK 15/13</b>	15	11	1250	13	Poly- V sez.K
<b>RVK 20/8</b>	20	15	2380	8	Poly- V sez.K
<b>RVK 20/10</b>	20	15	2140	10	Poly- V sez.K
<b>RVK 20/13</b>	20	15	1700	13	Poly- V sez.K

-- OIL SYSTEM CAPACITY: 4 litres

Recommended Oil Nuvair 546

For all other information, regarding the motor, consult the use and maintenance booklet of the manufacturer itself, enclosed with this documentation.

**COMPLETE MACHINE:**

-- MAX. ENVIRONMENTAL TEMPERATURE: 40 °C

### 3. PURPOSE OF THIS MANUAL

All owners and operators of this equipment, as well as maintenance and/or repair technicians, must carefully study this manual in order to understand the proper operation of this compressor and its capabilities and limitations.

By following the instructions in this manual, you will help to ensure your safety while using or working on this compressor system, and reduce risks in operation. Proper operation of this compressor will also help to extend its working life.

Keep this manual in a safe place. If you need a replacement copy you may contact Coltri/Nuvair at the address listed on the front of the manual. You can also download a replacement manual at [www.nuvair.com](http://www.nuvair.com) or [www.coltrisub.it](http://www.coltrisub.it). In order to ensure you have the correct manual, check the maker's plate on the compressor frame, or reference your original purchase invoice.

Maintenance of this compressor should only be performed by personnel who have the proper training and experience to do so. Any repairs must be performed by an authorized representative of Coltri Sub.

This machine has been specifically designed and built to supply compressed air under the operating conditions specified by the manufacturer. Any other use of this compressor for other purposes will be considered as "non-conforming," and will release the manufacturer from any further responsibility for consequential damage that may result to this equipment, or injuries that may occur to the user, or persons who have been supplied with compressed air provided by this compressor.

"Conforming use" presupposes the observance of the following regulations concerning the use, maintenance and transport of the unit itself.

It is also necessary to ensure that all the accident prevention regulations hereby described are followed, also in accordance with general safety regulations as indicated in the current legislation.

The manufacturer declines any responsibility in the event of any modifications made to the machine without its authorization.

The machine is supplied complete with the following documents:

- 1) - General use and maintenance booklet;
- 2) - Motor use and maintenance booklet;
- 3) - Declaration of machine conformity to the R.E.S. of EEC directive 89/392;
- 4) - Conformity certificate of the oil separator tank;
- 7) - Certificate of conformity of the safety valves of the oil separator tank;
- 9) - Compressor guarantee certificate.

## **4. OPERATIONAL LIMITATIONS**

The RVK compressor is a machine that generates a specific quantity of air (dependent on the model), which is measured in liters per minute. The compressed air from these machines is primarily designed to operate tools and other accessories that use compressed air, i.e., commonly known as “pneumatics.”

Each compressed air tool is designed to use a specific amount of air and this is measured in liters per minute. For the best performance of your tools, the compressed air consumption of the tool should not exceed 85% of the volume of air generated by the compressor. Keep in mind that as tools age, unless they have been properly maintained, they will wear and consume more air per minute.

A correct compressor/tool ratio will ensure that the machine operates efficiently and will help to guarantee maximum performance.

If the tool requires too much air, this will create a greater drain on the compressor and shorten its working life. In addition, the tool will not operate at its full capacity because it will not have sufficient pneumatic power.

This machine has been designed to work at an environmental temperatures of between -10 and +40 degrees C ( 14 - 104 degrees F).

### **COUNTER-INDICATIONS**

The compressed air generated by this unit contains minute traces of oil and it is therefore not suited to use in those systems that require totally oil-free air without filtration (i.e. food industry, pharmaceutical industry, flour and powder transport, etc...).

### **PRECAUTIONS**

#### **5.0 GENERAL PRECAUTIONS**

- 1) The owner of this compressor is responsible for ensuring that the unit is maintained in such condition as to ensure the safety of the operator and other who may be nearby. Any parts or accessories that are not operating properly must be replaced before further use of the system.
- 2) Use only the oils and lubricants recommended by Coltri/Nuvair and the engine manufacturer. Ensure that the selected lubricants comply with all current safety provisions, particularly in regards to fire, as well as proper disposal, decomposition, and the development of harmful gases.
- 3) The owner/supervisor of this machine must ensure that all proper operating and safety procedures are followed when using this system. All electrical wiring, piping, connectors, hoses, consumable items, and other accessories that are used in conjunction with this compressor must be in proper working condition.
- 4) Any maintenance on this system must be undertaken by a qualified individual. Any repairs on this system must be performed by a representative of Coltri/Nuvair.



**WARNING**

When performing maintenance on this compressor system, the entire system must be “locked out” and “tagged out” at the main breaker switch. There must be a sign affixed to the switch that reads, “Work in progress- Do not start up!” There must be no possibility of power being supplied to the system. In addition, the compressor machinery itself must be at a standstill. Failure to follow these precautions may result in extreme personal injury or death.

**WARNING**

In the event you suspect the compressor has overheated, or there is evidence of this due to odors (smell) or visible smoke, do not open any inspection hatch before the necessary cooling time has elapsed. This will help to prevent the risk of fire and/or explosion due to oil vapors coming in contact with fresh air. Failure to follow this precaution may result in extreme personal injury or death.

**WARNING**

Before proceeding to work on any pressurized component in this system, the compressor needs to be suitably isolated from all pressure sources and all components must be at normal atmospheric pressure. Each isolation valve in the system must be “locked out” and “tagged out” with a warning sign, “Work in progress – do not open!” Failure to follow this precaution may result in extreme personal injury or death.

5) Never allow the machine to operate beyond the established limits of temperature, maximum pressure, or speed.

6) Be sure to keep the machine, and any associated pneumatic appliances, clean and free of oil, dust, or accumulated dirt.

7) In order to avoid excessive working temperatures, the machine’s heat transfer surfaces must be regularly cleaned and inspected. This includes the cooling fins, coolers, water jackets, etc. A regular schedule must be established and followed for cleaning these components. If this schedule is not followed you will shorten the life of the compressor.

8) All the regulation and safety instruments must be maintained with the greatest care to ensure their correct function and they must not be placed out of use.

9) Take care in avoiding damage to the safety valves and other pressure discharging instruments. The air outlets must not be blocked by varnish, oil residue, or dirt. These contaminants will directly affect the working efficiency of the compressor.

10) Both the pressure and temperature indicators must be regularly checked for proper operation. They must be replaced immediately if they are not working properly.

11) Only spares manufactured by ROTAIR S.p.A. may be used in performing repairs on this compressor.

12) Never use any flammable solvents or carbon tetrachloride to clean any part of this compressor. Take precaution against toxic vapors when using any chemicals to clean this unit. Read the Material Safety Data Sheet (MSDS) for any cleaning agent and wear appropriate hand, eye, and respiratory protection if necessary. Use good ventilation.

## **WARNING**

**Wear appropriate hand, eye, and respiratory protection when using any chemical agents to clean this compressor. Failure to follow this precaution may result in extreme personal injury or death.**

13) Use extreme care to protect the internal components of this compressor when performing maintenance and repairs. Always protect internal components by covering the parts and exposed openings with a clean cloth, paper, or adhesive tape (only use tape that will not leave any residue).

14) During operations that may expose the compressor to flame or sparks, all components must be protected with non-flammable materials.

## **CAUTION**

**When dismantling the compressor, engine, or other components, avoid moving mobile parts that weigh in excess 15 kg (33 pounds) unless you have assistance from another person or have some type of hoisting equipment. Wearing gloves is a good precaution against cuts to your hands while lifting or handling heavy components.**

## **CAUTION**

**Once you have completed any repairs or maintenance, you must ensure that no tools, drop cloths, or components have been left inside or on top of the machine, engine, or other drive elements. Failure to do so can result in damage to the machine and may result in personal injury due to objects being thrown about.**

## **5.1 PRECAUTIONS DURING USE AND FUNCTION**

### **WARNING**

**Do not place yourself in the path of compressed air from this machine. Compressed air may drive foreign objects, or the air itself, into your body. Failure to follow this precaution may result in extreme personal injury or death.**

### **WARNING**

**Never operate this compressor in closed environments where vapors from corrosive or explosive gases may exist. This may result in an explosion. Failure to follow this precaution may result in extreme personal injury or death.**

1) This machine has been designed to work with the bonnet (cover) lowered (closed) and in place. Without the cover in position, the machine will not be ventilated properly and this could lead to damage to the system.

### **WARNING**

**Never operate the machine without the cover and doors in the closed position. This will expose you to high noise levels, which could lead to hearing loss. In addition, an open cover exposes the operator to rapidly moving parts. Failure to follow these precautions may result in extreme personal injury or death.**

2) The cooling fan is controlled by an automatic thermostat and may start or stop at any time.

### **WARNING**

**Never operate the machine without the cover for the cooling fan in place and properly secured. With the fan exposed, you could be seriously injured if it should start when you have any part of your body or clothing close to the fan. Failure to follow this precaution may result in extreme personal injury or death.**

3) The compressor needs to be installed in a location where there is free air circulation all the way around it. The closest wall should not be closer than 61 centimeters (two feet). The hot air discharged from the engine and cooling system must vent to the outside of any structure where the compressor is housed. Failure to properly vent the system and provide adequate fresh air for cooling purposes may result in the compressor overheating.

4) When selecting a flexible hose to connect to a pneumatic tool, the hose must be of the correct internal diameter (I.D.), length, and working pressure as specified by the manufacturer of the tool. If the hose is too small in internal diameter, or too long, the air flow will be blocked and the tool will not work properly. Never use worn, damaged, or faulty hoses.

**WARNING**

**All hoses connected to the outlet of this compressor must be capable of carrying sufficient pressure as delivered by the compressor. In addition, the hose must be in good condition with no cuts, nicks, or cracks and the fittings must be securely attached. If the hose ruptures, this could cause serious bodily injury.**

5) The hose used to connect the compressed air from the compressor to the tool must be equipped with a suitable shut-off valve at one end. The valve must be securely closed when connecting the hose to the tool.

**WARNING**

**Any hose used to supply air pressure to a pneumatic tool must be equipped with a shut-off valve at one end to help prevent the hose from whipping about when the compressor is turned on. If the valve is accidentally opened when the hose is not connected to the pneumatic tool, the hose will thrash about and may strike the user. Failure to follow this precaution may result in extreme personal injury or death.**

**WARNING**

**The noise output from this compressor and the tools used with it may exceed 85 db (A). Be sure to wear appropriate ear protection to avoid hearing loss and limit your exposure to this noise level.**

## **5.2 SAFETY DURING MAINTENANCE AND OPERATION**

Maintenance and repair operations are to be undertaken solely by properly trained staff, supervised by a specifically trained technician in the field if repairs are necessary.

1) Use only the correct tools specifically suited to the maintenance and repair operation you are performing. Avoid using adjustable wrenches and use the correct size wrench whenever possible. Do not use a wrench in place of a hammer.

2) Use only spare compressor parts manufactured by ROTAIR S.p.A.

3) All maintenance operations must be undertaken when there is no power to the compressor and the machine is at a complete standstill. Whenever maintenance operations must be performed, all electrical power to the machine must be “tagged out” and “locked out.”

### **WARNING**

**When performing maintenance on this compressor system, the entire system must be “locked out” and “tagged out” at the main breaker switch. There must be a sign affixed to the switch that reads, “Work in progress- Do not start up!” There must be no possibility of power being supplied to the system. In addition, the compressor machinery itself must be at a standstill. Failure to follow these precautions may result in extreme personal injury or death.**

### **WARNING**

**Before proceeding to work on any pressurized component in this system, the compressor needs to be suitably isolated from all pressure sources and all components must be at normal atmospheric pressure. Each isolation valve in the system must be “locked out” and “tagged out” with a warning sign, “Work in progress – do not open!” Failure to follow this precaution may result in extreme personal injury or death.**

4) Always ensure that no parts, cloths or tools have been left inside or on top of the unit at any time.

5) Do not remove or tamper with the sound-proofing material.

6) Always be sure to replace all the parts removed during maintenance oper

## **6.0 TECHNICAL DESCRIPTION**

### **6.1 CHASSIS AND CANOPY**

The chassis and the canopy are made of shaped and electro-welded sheet metal. Both parts are subject to two painting treatments to help guarantee the corrosion and rust resistance. The canopy has been planned to meet all requirements of normal maintenance as well as repairs: it is equipped with big doors on all sides to ensure easy accessibility to all parts of the compressor.

### **6.2 COMPRESSION UNIT AND OIL SEPARATOR TANK**

This compressor was completely manufactured in the ROTAIR S.p.A. factory and consists of a central body (cylinder), inside which are fitted two screw rotors with an asymmetric section, a male one with 5 lobes and a female one with 6 lobes.

The cylinder is closed at the ends by two head sections which contain the bearings which bear the radial and axial loads created by the air compression.

A series of channels, inside the cylinder and heads, deliver the oil to the various components. The distribution of the lubricant, serves to lubricate the bearings and to maintain a coating of oil between the rotors and the bearings themselves as well as the internal cylinder walls, thereby promoting compression resistance. Another important function of the oil injected between the rotors is that of absorbing the heat generated by the air compression.

The compressed air supplied by this compressor is free of any pulsations and compression comes about axially. The engine and the compression unit are linked by means of a transmission belt system.

The oil tank is integrated on the same compression unit, on the lower part, as is the oil separating filter, the minimum pressure valve, and safety valve located on the rear part of the compression unit.

A thermostatically controlled fan is mounted on the compression unit to control the quantity of air taken in according to the amount of air consumed. A double-stage filter mounted on the top of this unit guarantees maximum purity of the air.

**The oil tank is integrated on the same compression unit, on the lower part, as is the oil separating filter, the minimum pressure valve, and safety valve located on the rear part of the compression unit.**

**A "regulator" unit is mounted on the compression unit, the purpose of which is to regulate the quantity of air taken in according to the amount of air consumed. A double-stage filter mounted on the top of this unit guarantees maximum purity of the suctioned air.**

### **-- 6.3) BELT TRANSMISSION --**

The motor is connected to the compressor by means of a belt transmission. The motor and compressor are installed on a slide support which guarantees the coaxiality of the same and the perfect alignment of the belts in relation to the pulleys. A simple pulling system ensures perfect belt tensioning.

### **-- 6.4) FAN AND HEAT EXCHANGER --**

The required amount of electro-compressor cooling is guaranteed thanks to a fan located near the heat exchanger. The airflow generated, which passes through the combined air-air and air-oil radiator cools the air on exit from the compressor as well as the machine.

### **-- 6.5) AIR TANK --**

On request the RVK compressor may be supplied with a horizontal air accumulation tank with a 270 litre capacity and tested to C.E 87/404 standards to a pressure of 11 bar. The tank is fitted with a safety valve and a manual discharge cock.

### **-- 6.6) DRYER --**

On request the RVK compressor is supplied with a refrigerating cycle dryer with the following features:

- nominal air entry temperature	35 ° C
- maximum air entry temperature	45 ° C
- nominal environmental pressure	25 ° C
- maximum environmental pressure	45 ° C
- nominal working pressure	7 bar
- max. working pressure	15 bar
- pressurized dew point	3 ° C

For further information on the dryer, consult the relative user and maintenance manual enclosed.

### **-- 7) CONTROL INSTRUMENTS AND DEVICES --**

The control panel is located on the front section, and has been positioned in such a way as to ensure easily accessible control function.

It is visually divided into two parts:

At the top are the indicator leds and the control buttons, while the hour-counter, the gauge and the emergency button are positioned under the wording *ROTAIR S.P.A.*

## -- 8. ELECTRONIC CARD DESCRIPTION --

Fig.2 shows the adhesive under which the electronic card is positioned, this card is necessary for control and command function by means of 3 buttons, the signal function is by means of luminous leds.



fig. 2

A) INDICATOR LEDS: a total of 7 are present and the table at the side of the same indicates the led ON function. The lighting up of led 1 indicates that the machine is live and led 2 indicates that the running button has been pressed and that the compressor cycle has been engaged.

Led 4 indicates that the emergency button has been pressed while led 6 indicates that the maximum permitted temperature has been exceeded.

While leds 5 and 7 respectively indicate motor overcharge and possible faulty connection of the power phases.

B) CONTROL BUTTONS : are located to the right of the leds, and are drawn directly onto the adhesive, the function of which is as follows (from top to bottom).

- **RUNNING:** The machine starts on pressing this button.
- **STOP:** to stop the machine. Bear in mind that the stopping function is timed to permit the solenoids to de-pressurize the machine (chap. 3.3 STOP)
- **RESET:** resets any eventual leds that may be on indicating anomaly. After eliminating the cause of the fault it is necessary to press this button.

## **9) MACHINE INSTALLATION --**

### **9.1 - CHOICE OF PREMISES -**

During compressor operation the heat generated by the compressor is transmitted to the surrounding air. In the case of compressors installed in premises of limited size, it is necessary to eliminate this heat in order to limit the increase in the environmental temperature. The machine should therefore be installed, leaving a sufficient free space around it, for the necessary ordinary and extraordinary maintenance operations. The premises must therefore be sufficiently ventilated by means of windows and ventilation inlets. Sometimes such ventilation inlets are inadequate and it will therefore be necessary to make use of channels of adequate section so as to take in fresh air from outside and to expel the hot ventilated air from inside the premises.

The premises in which the compressor/s is to be installed must always be positioned in such a way as to ensure that it possible to take in ventilation air from outside, without having to make use of excessively long channel elements. The ventilation inlet should, preferably be located on a wall that faces North, so as to prevent the risk of the intake of too much hot air during the summer months.

The air inlet must be built into a wall of the premises at ground height, while the air outlet will be built into the upper part of the opposite wall.

### **9.2 - DISTRIBUTION NET CONNECTION -**

Compressed air connection must be made using piping of a sectional dimension that is not less than that of the exit piping from the compressor station.

It is always advisable to avoid this piping being of excessive length, so that it is advisable to install the machine as near as possible to the compressed air tank.

Should the use of a very long distribution net be necessary, in order to avoid any harmful pressure drops, it will be necessary to use piping of sufficiently large diameter and to avoid sharp bends and elbows.

When preparing the pipe sizes it is important to ensure that the speed of the air inside the same is maintained below 10 metres per second.

Furthermore in the preparation of the mains network it is necessary to ensure that the piping is made to slope downwards to facilitate condensation discharge.

Atmospheric air in fact contains water vapour which, as the result of cooling after compression, turns into water which must be discharged from the system.



### 9.3 - CONNECTION TO MAINS NETWORK -



- Check that the voltage of the power line corresponds to that indicated in the wiring diagram attached to the machine.
- The electric cable must be inserted into the cable-guide formed from the lower panel of the bodywork (part. 2 fig. 3). Remove the flap on the right side of the compression station (part. 1 fig. 3), and thread the cable through the relative cable-guide located at the base of the electric panel and connect up the cables on the fuse-holder FUL1 (part. 1 figure 3.1). The cable section should be calculated in accordance with current electrical regulations.
- Connect the earthing cable to the system (yellow/green terminal)



A line isolator must be installed near the unit and in a clearly visible place, complete with fuses or magnetic switch.

## -- 10) MACHINE USE INSTRUCTIONS --

The use of this electro-compressor does not require specialized personnel; however it is essential that the person responsible for its operation has read the manual in order to put into practice all the advice and instructions provided.

Reference will be made to fig.2 in this chapter.

### **10.1 PREPARING FOR START-UP**

1. Check the oil level inside the tank.
2. Check that the earthing system of the electric system is adequate.
3. Check that the oil tank emptying tap is fully closed.
4. Ensure that the maximum final pressure of the unit is compatible and does not exceed the value as required by any machinery, equipment or safety valves mounted beneath the unit itself.
5. **In the event of start up following an oil change or after a long period of inactivity, pour in about 0.5 litres of oil into the screw set before starting. To do this, remove the air filter and using a hand pump or other suitable means push the regulator plate downwards whilst pouring the oil in at the same time.**

### **10.2 STARTING UP**

The operations necessary to ensure the correct starting up of the machine are as follows:

- **Power the electro-compressor.**  
Led 1 will come on (voltage). Should led 7 also light up it will be necessary to invert the power phases of the electro-compressor, after disconnecting the mains power.  
If led 4 lights up it means that the emergency button has been pressed, simply disconnect it (rotating it and pushing it towards you) and press the RESET button to restore machine function.



**IMPORTANT:**

It is important to remember that during the initial starting up stage and in the event of all prolonged periods of inactivity of at least one week, it is strongly advisable to keep the air cocks closed, before pressing the operating button.

- **Press the "RUN" button**  
The motor starts. The starter located inside the compartment (right side of the electro-compressor), has the main function of starting the motor in "star" mode to then pass into "delta" mode.

Once the star-triangle exchange has occurred, the electro-valve opens the suction for about 2 seconds, the compressor reaches a pressure level of 3.5-4 bar and maintains it for 15 seconds, after which the suction is opened up to the maximum set pressure. From this moment the electro-compressor operates according to the operating cycle. On the control panel, after pressing the RUN button, led 2 lights up to indicate active machine cycle.



#### IMPORTANT:

In the case previously mentioned of initial start or extended machine stoppage, on starting the electro-compressor wait at least 1 minute before opening the air cocks in the direction of the mains. Remember to open the cocks very gradually!

After pressing the run button the machine may not start and led 3 will come on. It means that the air pressure inside the line exceeds the minimum pressure value set on the electronic card (wait for this pressure to fall and check to ensure that the machine re-starts after reaching the minimum pressure level) or that the oil pressure inside the tank exceeds 1.5 bar and the sensor impedes its start. The electro-compressor will start up only when the exhaust solenoid reduces the pressure to below 1.5 bar. There is a gauge inside the machine which indicates the pressure inside the oil tank.

### 10.3 OPERATING PHASE

As mentioned, 6 seconds after the engagement of the “star-delta” the solenoids are engaged, the suction valve opens and the electro-compressor begins air compression. The pressure indicated on the gauge begins to rise until it reaches the maximum set value. At this point the electronic card disengages the solenoids: one of which acts to close the suction valve and the consequent flow of air directed for compression and the other operating to de-pressurize the oil-pneumatic system. From this moment the compressor can be said to be running “on empty” as the result of the low pressure reached inside the tank which allows the engine to “save” 65% as compared to the power absorbed at full load.

When the air pressure inside the mains falls to below the minimum pressure value set on the electronic card, this last engages the solenoids and the cycle is repeated.

Should the pressure inside the mains remain above the minimum value for over 4 minutes, it means that the air demand by the users is low as compared to the actual mains capacity and the electro-compressor will therefore come to a stop and led 3 will come on. Should the pressure fall to below a minimum set value, the electro-compressor will automatically re-start and is ready to supply compressed air to the line. Such function is termed “*timed empty running*”, and generates further energy savings, over and above the “*empty*” running function.

### 10.4 STOPPING

#### ▪ Press the stop button

Led 2 will go out, but the electro-compressor will continue to function for a further 60 seconds. This is the time necessary to de-pressurize the oil-pneumatic system as stopping under pressure is highly detrimental to the machine, as well as to the motor, the screw set and the oil separator filter.



The machine can only be stopped by using the red emergency button (fig. 2); in which case the machine will come to an immediate stop whilst under pressure with all the consequent problems. Stopping by means of the emergency button is only possible in the case of a fault or danger situation.

After the machine stops it cannot be immediately re-activated and it will be necessary to wait a few seconds to allow the pressure inside the tank to fall to under 1.5 bar (led 3 will come on).

## -- 11. SAFETY DEVICES AND MAIN MALFUNCTION DISPLAY --

- **High pressure:** There is also a mechanical safety valve on the tank for discharging any accidental unwanted overpressure. This valve has been set according to very specific requirements and therefore must not be altered or tampered with for any reason.
- **Minimum pressure:** the device positioned on the tank prevents the starting up of the machine until the pressure inside the tank falls to under 1.5 bar.
- **High oil temperature:** there are two types of high oil temperature situations. The first concerns the high temperature inside the tank. The electro compressor will come to an immediate stop should the temperature exceed 105°C.  
The second situation stops the machine when the temperature inside the compression screw exceeds a value of 115°-3°C. Such a situation will immediately bring the machine to a stop and led 6 will come on.
- **Motor overload:** the thermal relay on the electrical system sends a signal to the electronic card which interrupts the compression cycle and causes led 5 to come on. This relay prevents any kind of motor overloads which may damage it..
- **Rotation direction:** Each time that the compressor is connected to the electrical line, it is important to pay careful attention to led 7. If it comes on it means that the two phases have been inverted and the motor can no longer start up. This device prevents the motor from turning in an opposite direction to the rotation direction of the compression unit, thereby preventing any serious and irreparable damage to the entire Rotary Screw system.



### WARNING:

It is important to remember that it is essential to stop the machine by means of the STOP button before all ordinary maintenance operations.

- **Fuses:** 3 primary fuses, gauged on the basis of the total absorbed power of the compressor, which protect the entire electric power plant from the risk of short circuits and overloads, while a series of 4 smaller fuses protect the auxiliary system such as the transformer, electro-valves etc. The electronic card protection is by means of 2 fuses placed on the card itself.

## **-- 12) MAINTENANCE PROGRAM --**

This programme indicates all the necessary periodic operations to be undertaken in the machine and which are essential to ensure its efficient function and long life.

### **ORDINARY MAINTENANCE**

Can be undertaken by the personnel who operate on the machine and includes all those periodic programmed maintenance operations such as checks on the oil level, air filters, refuelling, cleaning operations and checks to isolate any eventual leakage of lubricant or fuel inside the machine.

Here follows a list of all the operations relating to the compressor part, in order of frequency, while for those relating to the "motor" please refer to the USER AND MAINTENANCE MANUAL, supplied by the motor construction company with the machine.

### **-- 12.1) DAILY CHECKS --**

#### **-- 12.1.1) DAILY AND BEFORE STARTING UP THE MACHINE --**

- Check on the compressor oil level (paragraph 13.1).
- Check for any lubricant leakage.

#### **-- 12.1.2) DAILY AND WITH MOTOR RUNNING --**

- Check on all the indicator lights positioned on the control panel
- Check on the maximum pressure level
- Check on the minimum pressure level

### **-- 12.2) WEEKLY --**

- Check on air compressor filter (13.11).



**WARNING:** *Should the compressor operate in a very dusty environment the air filter must be checked, cleaned or replaced more often than indicated above.*

### **-- 12.3) EVERY THREE MONTHS --**

- Safety valve efficiency check .
- Oil cooling radiator cleaning (13.6).
- Check on the oil recovery nozzle (13.8).

**-- 12.4) ANNUALLY OR ACCORDING TO THE PLANNED FREQUENCY ACCORDING TO HOURS OF OPERATION -**

As concerns the motor refer to the manufacturer's user and maintenance manual.

After the first **50 HOURS:** Compressor oil filter replacement.  
Compressor oil replacement.

Every **500 HOURS:** Compressor air filter replacement (13.11).



**WARNING:** *The replacement of the compressor air filter can also be undertaken more often, according to the amount of dust in the working environment.*

Every **2000 HOURS:** Compressor oil replacement (13.2).

Every **2000 HOURS:** Oil separator element replacement (13.4).

Every **2000 HOURS:** Compressor oil filter replacement (13.3).

Every **3000 HOURS:** General check on the various components by the "Authorized Rotair" assistance service.



**WARNING:** *during the various maintenance operations it is necessary to carefully examine the rubber piping and should it be found to be excessively hardened and rigid, they must be replaced with materials having equivalent technical features.*  
*The piping must be in accordance with SAE 100 R1 standards.*

## -- 13) CHECKING AND MAINTENANCE --

### -- 13.1) CHECKING COMPRESSOR OIL LEVEL --

Every morning before starting the machine check the oil level in the compressor tank. The compressor oil level shall never fall below the minimum level notch and never exceed the maximum level either. It shall fall between the two notches of min. and max. level.

**Oil level checks must be undertaken a few hours after having stopped the machine, in order to allow the oil to flow into the tank. In fact if the oil level is checked immediately after switching off the machine, a false reading is given which means that the user will top up with more oil than is necessary.**

### -- 13.2) CHANGING COMPRESSOR OIL --

The oil in the compressor shall be changed every 2000 hours' operation or at least once a year. To change the oil proceed as follows:

1. Change the oil when the machine is hot
2. switch off the compressor and disconnect the main switch.
3. Unscrew the oil plug on the tank side (part. A fig.3) after checking that the inside of the tank has been fully depressurised
4. Open the drain valve on the tank bottom (part.B fig.4)
5. After draining the oil replace the oil filter cartridge by unscrewing and removing it from its seat. Replace with a new one (13.3)
6. Fill with oil through the filler.

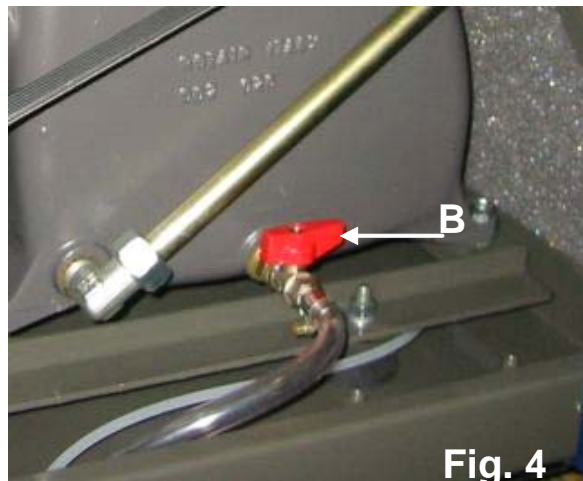
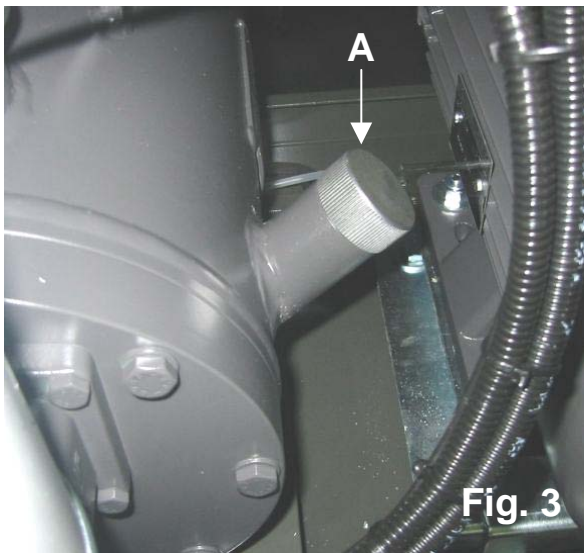

**IMPORTANT:** Always use the same brand and type of oil as indicated in paragraph 2. In the event that it is necessary to change the oil type (which must however be of an equivalent type as indicated in paragraph 2) be sure to drain away all the lubricant from the entire circuit before adding a different type.

**NEVER MIX DIFFERENT OIL TYPES.**

### -- 13.3) COMPRESSOR OIL FILTER REPLACEMENT (Fig. 5) --

- Use a chain pipe wrench to unscrew the filter to be replaced (part A).
- Oil the seal of the new filter which must be tightened and secured **by hand only**.
- Start up the machine and ensure that there is no leakage near the seal; if there is; switch off the machine and check the condition of the machine and that it is correctly positioned in its slot.

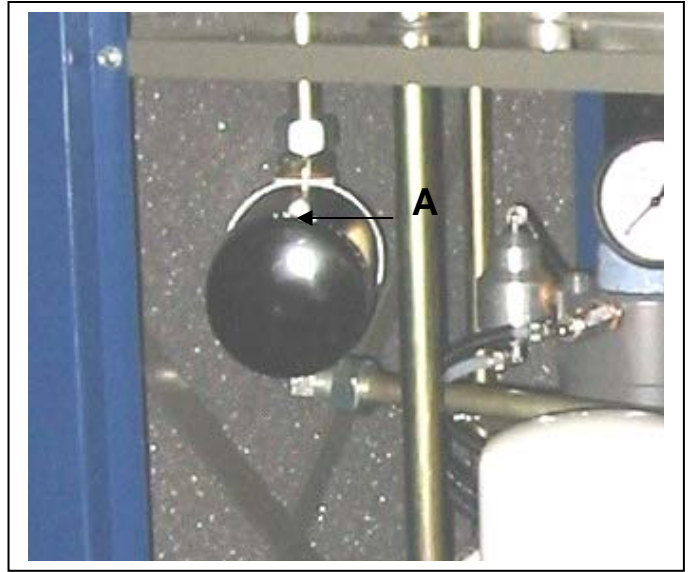

FIG. 5



**WARNING:** *The old filter is impregnated with polluted and harmful mineral oil. It must therefore be sent to the special collection centres.*

### -- 13.4) OIL SEPARATOR ELEMENT --

#### -- 13.4.1) CHECKING OF OIL SEPARATOR ELEMENT --

This operation is reserved for specialised and qualified personnel.

The frequency is usually estimated as being of about every 2000 working hours, but it strictly depends on the observance of all the maintenance regulations indicated in this manual.

Insufficient oil in the tank, failure to comply with the lubricant replacement frequency indications or use of the machine with clogged cooling radiator, may all result in **serious damage** to the separator filter.

**Therefore after having checked the condition of the recovery nozzle described in and having made sure of the correct oil level in tank, should there be any further traces of oil in the compressed air, it is necessary to replace the oil separator filter.**

To find out the degree of blockage of the oil separator filter proceed as follows:

- install a gauge at the top of the oil separator and check that the one on the machine is efficient.
- Start up the machine
- Partially open the delivery piping until the control panel gauge indicates the working pressure.
- Read the pressure on the gauge positioned at the top of the oil separator and compare the two values: should a difference of over 1 bar be found, it is a clear indication that the filter is blocked and it must be neither cleaned or washed, but replaced.



**-- 13.4.2) INSTRUCTIONS FOR THE REPLACEMENT OF THE OIL SEPARATOR ELEMENT --**

1. This operation must be undertaken with the machine at a standstill, and with no pressure inside the oil separator tank.
2. To prevent the risk of soiling the machine as the result of oil leakage which may occur on the replacement of the oil, we recommend that a few cloths be placed under the compressor unit.
3. Unscrew the oil separator filter (part. 1 fig.6).
4. Re-assemble the filter making sure to lubricate the filter element seal. The filter must be secured by hand only.

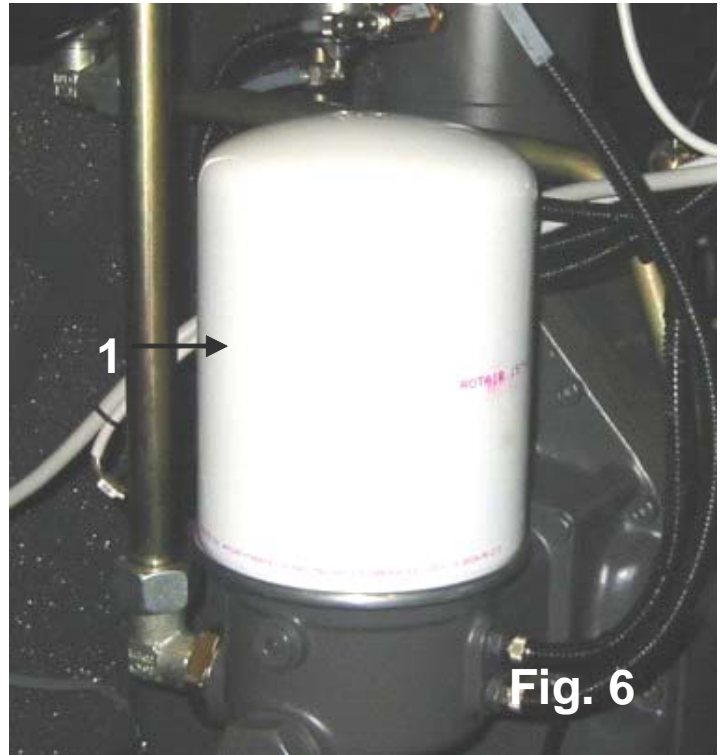

**Fig. 6**

## -- 12.5) INSTRUCTIONS FOR THE REPLACEMENT OF THE PRE-FILTER IN THE INTEGRATED UNIT

The inside of the integrated compression unit contains a pre-filter which carries out the initial air-oil separation process, thereby reducing the workload on the oil separator filter or permitting improved air-oil separation.

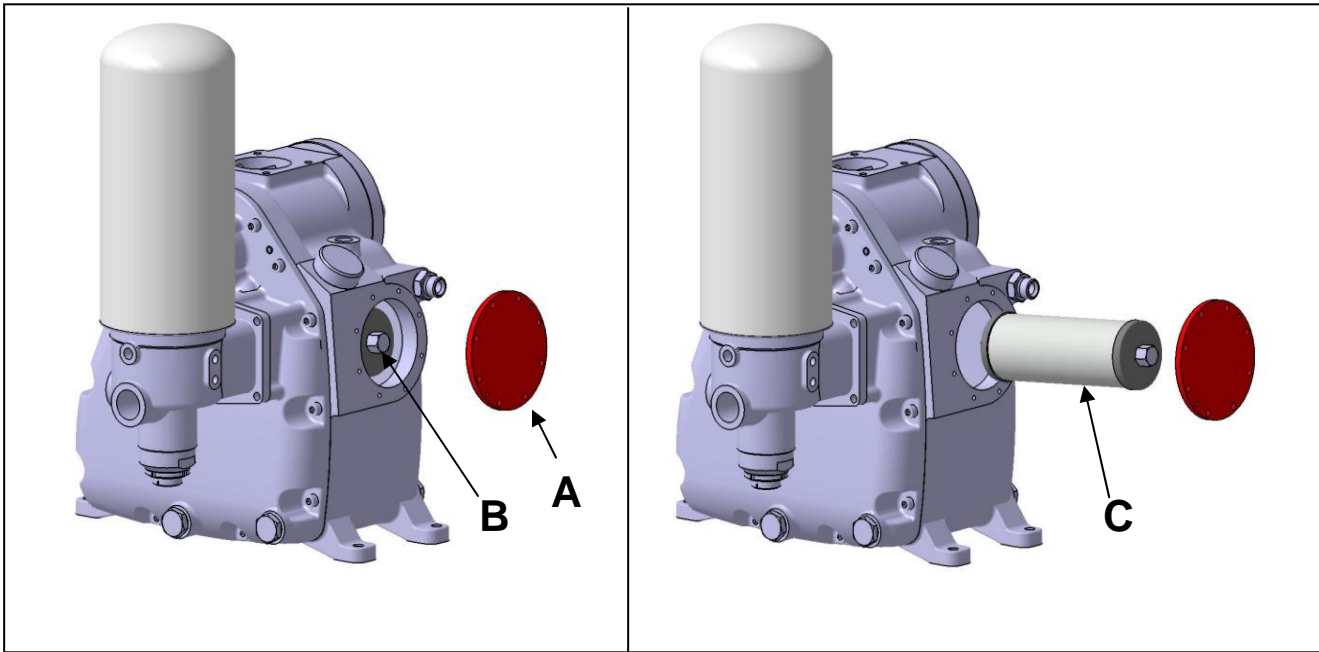

To replace the pre-filter proceed as follows:

After checking that there is no pressure inside the tank, loosen flange A using a 6 mm Allen wrench. Loosen filter C using the hexagon nut B using a 17 mm wrench and completely extract the same. Insert the new filter and tighten it on its slot. Re-tighten flange A.

**IMPORTANT: This operation must only be carried out once the machine has come to a complete stop and the power supply has been disconnected!**

## -- 13.6) COOLING RADIATOR CLEANING --

The cooling liquids of the compressor and motor are cooled by a radiator which must therefore be kept clean to ensure that the ventilation air can easily pass through its honeycomb flaps.

Should the flaps become clogged with dust or other particles, there is a risk of harmful overheating of the mechanical parts of the screw compressor, seriously jeopardising its function and duration. It is therefore advisable to check it regularly and clean it using compressed air or wash it using a pressurized water jet.

## -- 13.7) MINIMUM PRESSURE CHECKING AND SETTING --

The purpose of this valve is to ensure that during operation the pressure in the oil separator tank does not drop under the minimum value, in order to ensure the necessary oil circulation.

### CHECKING AND SETTING:

- 1) Start up the machine
- 2) With motor warm, at right temperature, gradually proceed to fully open the air cock the pressure of between 4.5 - 5 bar must appear on the gauge.

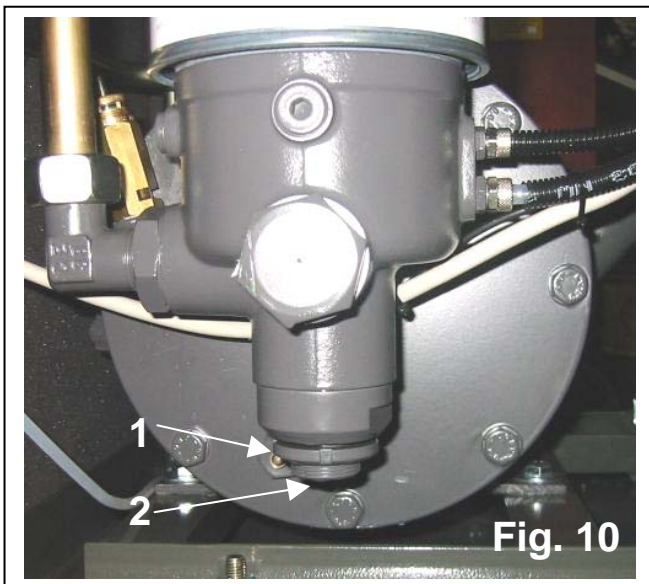

Should a different pressure appear than that indicated above, proceed with setting as follows (fig. 10):

- 3 Release the lock-nut (1) .
- 4 Tighten the regulation screw (2) to increase the pressure to the desired value.
- 5 Loosen the regulation screw (2) to reduce the pressure to the desired value
- 6 Tighten the lock nut (1) and close the cocks.
- 7 Slowly re-open the air cock and then close it again repeating the operations several times in order to permit the valve to settle into place.

### -- 13.8) OIL RECOVERY NOZZLE CHECKING AND CLEANING --

This must be undertaken in the event of any leakage of nebulized oil mixed with compressed air, as follows (fig. 11):

- Unscrew the connection (R)
- Inside the connection (R) is a nozzle (U); ensure that its gauged hole is not clogged (blow with a jet of compressed air).
- Re-assemble.

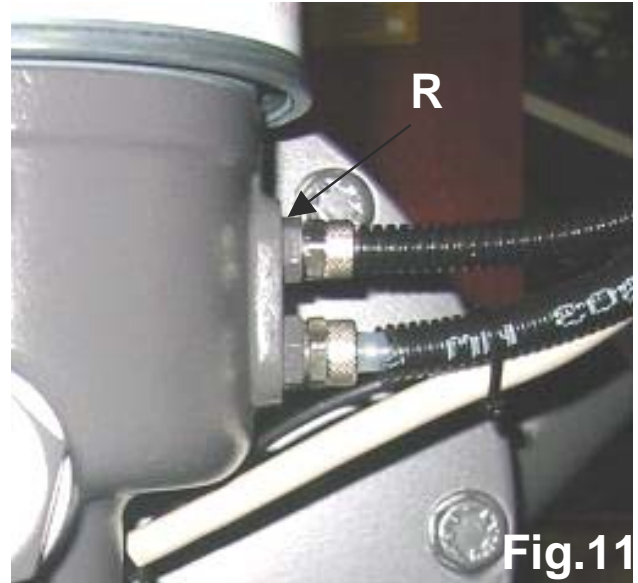

**Fig.11**



**WARNING:** During the regular function of the compressor it is normal to note a certain amount of oil flow out of the transparent piping which starts from the connection (R), towards the compressor head.

## -- 13.9) REGULATION OF THE MAXIMUM AND DIFFERENTIAL PRESSURE --

The unit is calibrated to the maximum pressure level requested by the client on order, during the factory testing stage.

**Should it be necessary to make a different regulation, the maximum level set for this type of compressor must never be exceeded, as indicated in chapter 1 of the present user and maintenance manual.** Setting to above the maximum values would cause serious overcharging of the electric motor.

### PRESSURE REGULATION INSTRUCTIONS:

Proceed as follows:

- Loosen the screw part. 1 fig. 12
- By rotating the regulation screw (part.2 fig. 13) in a clockwise direction will increase the pressure. Once the maximum desired level is reached the compressor will stop pumping.
- The pressure will be reduced by rotating the screw in an anti-clockwise sense.



Fig. 12 DIFFERENTIAL PRESSURE

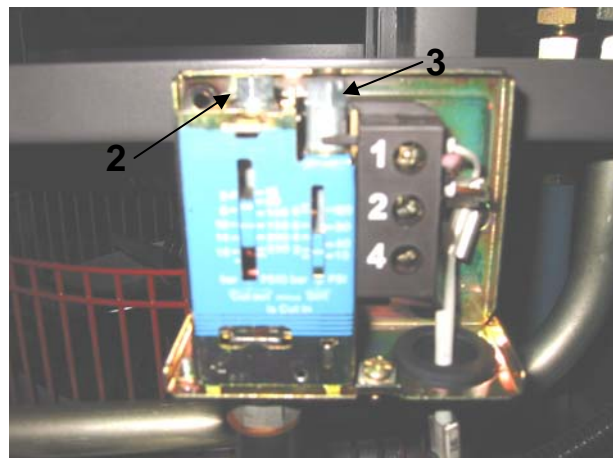

REGULATION INSTRUCTIONS: Fig. 13

This regulation is necessary to establish when the compressor will resume air pumping, on reaching the minimum pressure value.

The regulation of this differential pressure value is obtained by turning the regulation screw (Part 3) in a clockwise sense (to increase it) or in an anti-clockwise sense (to reduce it).

### **IMPORTANT:**

*The difference between the maximum and minimum pressure calibration value, must never be under 1 bar!*

### -- 13.10) SAFETY VALVE CHECK --

This valve is positioned on the oil separator tank and operates to discharge any accidental overpressure.

This valve is calibrated and checked at the factory, and cannot therefore be altered or tampered with for any reason.

Its efficiency can be checked periodically as follows:

1. Start up the machine
2. With cocks closed, lift the pin upwards using pliers and release as soon as the valve can be seen to discharge air.

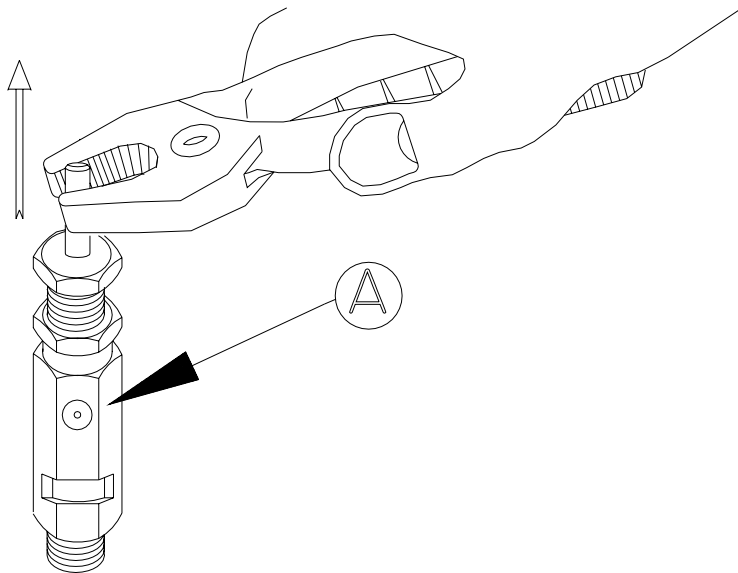

**WARNING:** The air which escapes from the valve during this checking operation is mixed with oil particles and therefore to avoid soiling the operator and the inside of the machine it is advisable to bind the valve with a cloth.

If the pin fail to rise after being guided with the pliers, thereby preventing valve breathing, it must be replaced at once. New replacement safety valves must be of the same type as the original and must be complete with conformity

certificate issued by the manufacturer.

As this valve plays a vital role in preventing any dangerous overpressure which could cause the piping, or the oil separator tank to burst, it is important to request the original spare part from ROTAIR S.P.A. citing the machine serial number.

ROTAIR S.P.A. will not accept any responsibility in the event of the use of non-original and non-conforming valves.

## -- 13.11) AIR FILTER MAINTENANCE --

The compressor life and efficiency greatly depends on an accurate maintenance of the air filter. A clogged filter reduces the efficiency and causes early wear of the compressor.

In normal environmental conditions, clean the air filter every 100 hours work and change the air filter after 500 hours work. In very dusty environmental conditions clean as often as required.

### FILTER DISASSEMBLY

1. Unscrew nuts
2. Extract the air filter

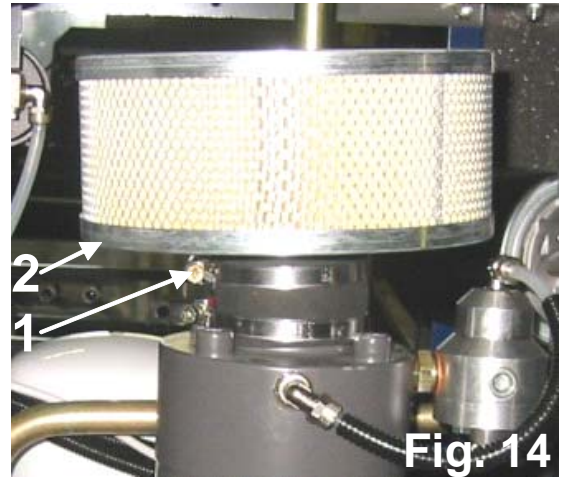

### FILTER CLEANING

Accurately blow the air filter inside out. The above operations should be carried out in the reverse order to fit them back again.

## -- 13.12) SUCTION FILTER AND ITS MAINTENANCE --

RVK compressors have been designed and made to operate in an environment at a max. temperature of 40°C;

should the machine be installed in a small ill-ventilated room because you have no other choice, it will be necessary to make a ventilation duct for air suction and a second duct for letting hot air out. Both ducts shall be connected with the outside and set in such a way as to prevent suction air from mixing with exhaust air. They shall have an adequate size with open-radius bends. An incorrect sizing would reduce ventilation and cause compressor overheating.

The room shall be well ventilated, clean and as close as possible to the electric distribution panel. Should the compressor operate in a very dusty environment, clean air shall flow freely: this can be achieved by replacing the filter often enough (on the vent).

**A dirty clogged filter reduces and slows down the quantity of air being sucked in necessary for ventilation with a consequent harmful overheating of the unit.**

**WARNING:** *type, density and thickness of the filter have been designed and selected not to create too much vacuum. Therefore the spares shall always be original ROTAIR S.P.A. spares. Should other materials be used the guarantee on the machine will become null and void.*

The machine shall be installed by leaving free space around it for ordinary and extraordinary maintenance operations.



## -- 13.13) TRANSMISSION BELT ---

### -- 13.13.1) CHECK OF TRANSMISSION BELT TENSIONING ---

For normal, efficient compressor functioning the transmission belts must always be perfectly tensioned..

**Tensions inferior or superior to those ones we recommend, could cause working anomalies like the sliding or the premature wear and tear of the belt. The mounting of the belt has to be made without using any instrument ( for instance levers ) that could incise the belt or the pulley.**

These instructions (Fig. 15) must be followed to determine the exact tensioning of the transmission belts.

**To determine the right tension, measure the arrow “*f*” caused by the application of a force “*Q*” in the middle of the free part of the belt. The force has to be perpendicular to the belt.**

Arrow *f* must be 1,5% of the free section “*l*” applying a *Q* force equivalent to 40 ÷ 47 N for RVK 8-10-15 and of 50 ÷ 63 N for RVK 20.

If the arrow value “*f*” exceeds the indicated value it means that the belts are slack, while if the value is lower than this it means that the belts are too taut.

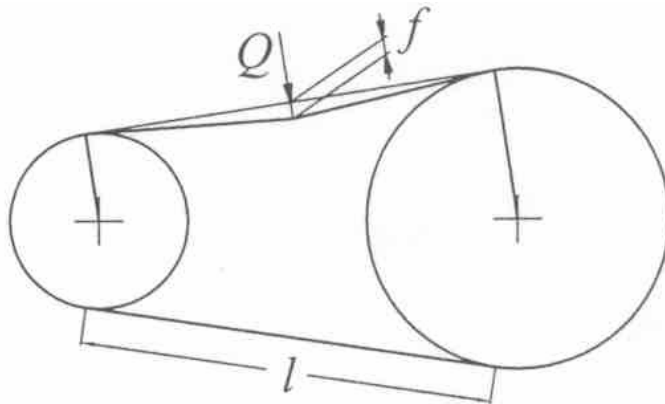

Fig. 15



#### **Warning:**

Belts that are too loose could slip and cause loss of compressor power.

Belts that are too tight deteriorate and consequently break.



Warning:

Check belt tension during the first 50 working hours

**Please note that the belts, above all during the first 50 working hours, undergo a slight setting-in and consequently mild stretching.**

**In this situation the belts may be subject to slipping and, as a result, overheating which could cause breakages.**

**This is why we strongly recommend the user, after no more than 50 working hours, to check and re-tension the belts. Once this operation has been carried out the belt length is stabilised and subsequent checks must be done following the instructions in the “Maintenance Programme” chapter.**

**For belt tightening see the instructions in the chapter “Tensioning and Replacement of Transmission Belts”**

#### TENSIONING AND REPLACEMENT OF TRANSMISSION BELTS

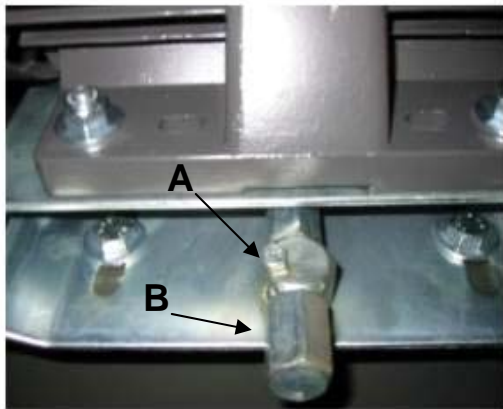
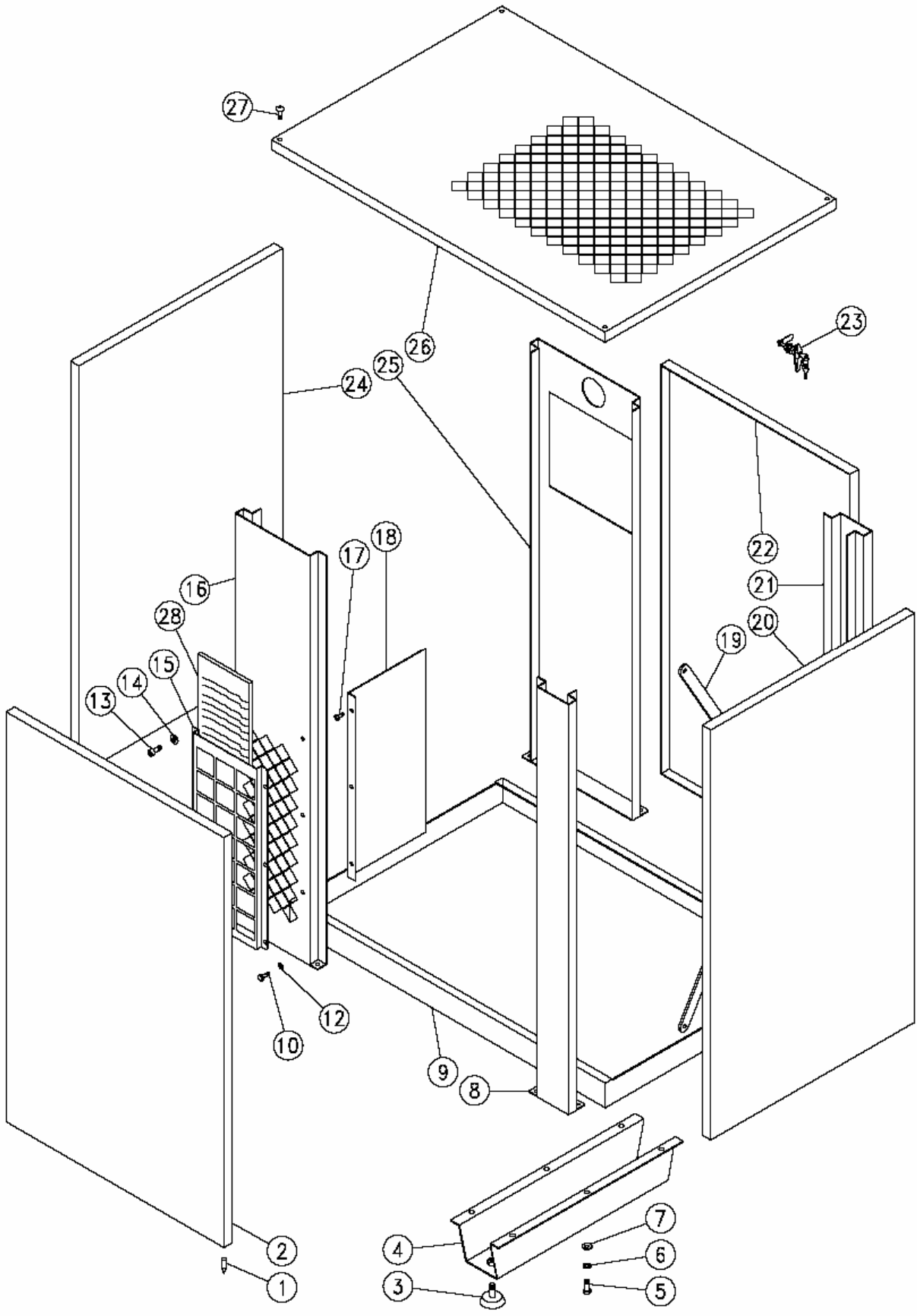

**Fig .16**

As regards the tension and the replacement of the transmission belts it is necessary to proceed as follows:

1. Loosen the screw (part. A fig 16).
2. Rotate the regulation screw (part. B fig.16) for tensioning.
3. If the belts have been replaced it is necessary to tension them to the correct value, proceeding as described at point 1 of this chapter and that described in the previous chapter under “Transmission belt tensioning check”.

4. On adjusting the belts to the required tension, firmly secure screw A.



# **ROTAIR S.p.A.**

## **DETAILS LIST OF RVKi 8-10-15-20**

**TAB. 1**

<b>POSITION</b>	<b>DESCRIPTION</b>	<b>CODE</b>	<b>QUANTITY</b>
1	M6 PIN FOR CENTERING PANELS	018-121-S	8
2	REAR PANEL	124-2033-S	1
3	FEET D.50	068-100-S	4
4	FOOT BEARING CHASSIS	068-120-S	2
5	T.E. SCREW 8X20	132-101-S	12
6	ELASTIC WASHER D.8	139-040-S	12
7	FLAT WASHER 8,4X17X1,5	015-030-S	12
8	REAR LEFT UPRIGHT PANEL	124-2081-S	1
9	CHASSIS	038-2810-S	1
10	TCEI SCREW 4X10	133-043-S	4
12	FLAT WASHER	015-028-S	4
15	INTAKE CLOTH SUPPORT PANEL	124-20381-S	1
16	REAR RIGHT UPRIGHT PANEL	124-20831-S	1
18	SOUND-PROOFED INNER SECTION	118-118-S	1
19	TIE ROD BODYWORK BLADE	120-157-S	1
20	LEFT SIDE PANEL	124-2034-S	1
21	FRONT LEFT UPRIGHT PANEL	124-2080-S	1
22	FRONT PANEL	124-2032-S	1
23	ALLEN SCREW LOCK	128-007-S	1
24	RIGHT SIDE PANEL	124-2037-S	1
25	FRONT RIGHT UPRIGHT PANEL TELMAT	124-2082-S	1
25	FRONT RIGHT UPRIGHT PANEL AIRMASTER VERSION	124-2084-S	1
26	UPPER PANEL WITH GRATING	124-2036-S	1
27	BUTTON HEAD SCREW 6X40	150-505-S	10
28	PRE-FILTER 780x172	162-9875-S	1

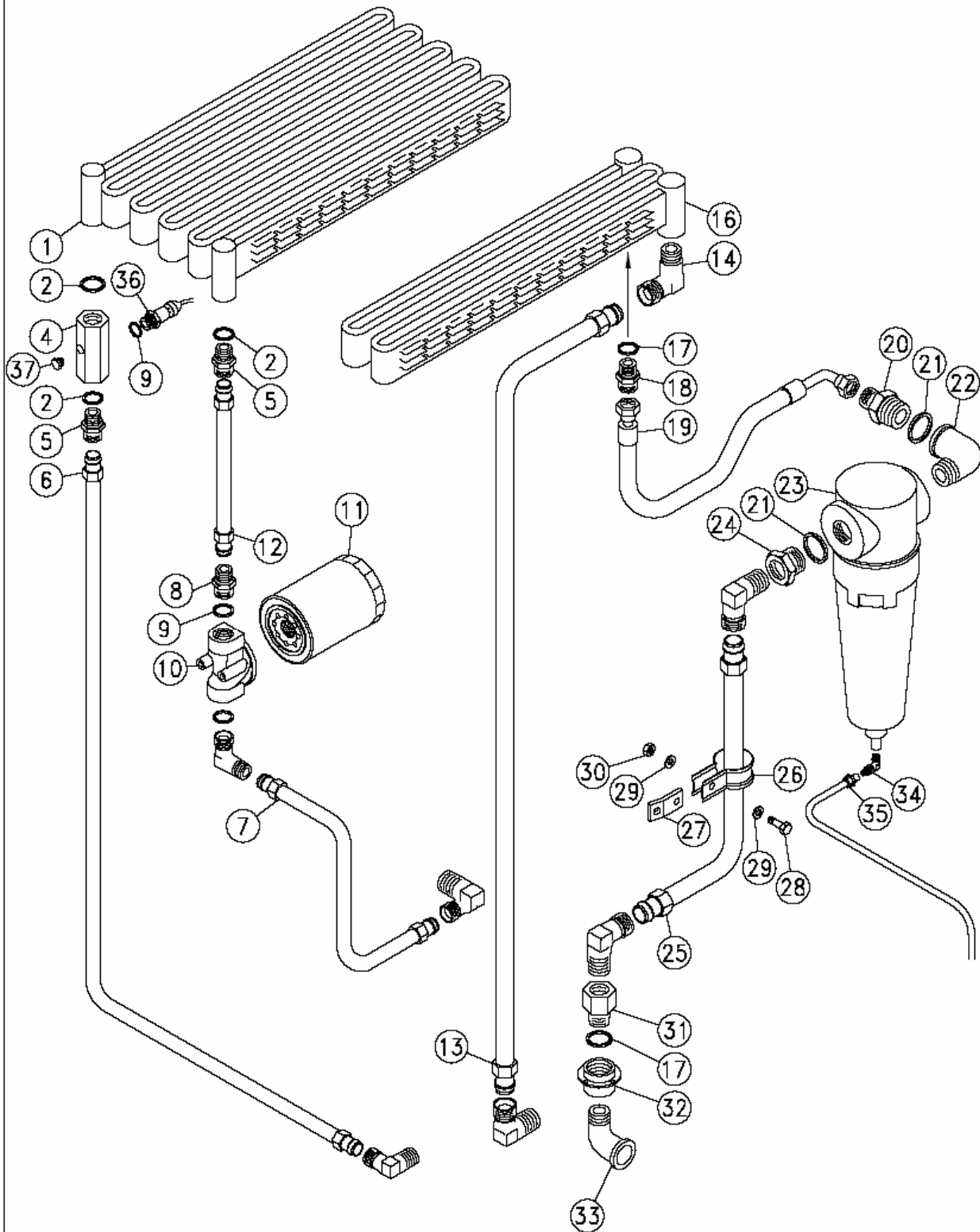

# **ROTAIR S.p.A.**

## **DETAILS LIST OF RVKi 8-10-15-20**

**TAB. 2**

<b>POSITION</b>	<b>DESCRIPTION</b>	<b>CODE</b>	<b>QUANTITY</b>
1	OIL RADIATOR RVK 8-10	011-0594-S	1
1	OIL RADIATOR RVK 15-20	011-0595-S	1
2	COPPER WASHER 1/2"	015-012-S	4
4	EXTENSION 1/2"M – 1/2"F	189-110-S	1
5	DOUBLE SCREW 1/2"	187-045-S	2
6	IRON PIPING RVK 8-10	064-0061-S	1
6	IRON PIPING RVK 15-20	064-0051-S	1
7	IRON PIPING RVK 8-20	064-0011-S	1
8	REDUCTION ELEMENT 3/4"M – 1/2"F	190-041-S	2
9	COPPER WASHER 3/4"	015-015-S	2
10	SUPPORT HEAD OIL FILTER	010-047-S	1
11	OIL FILTER	099-007-S	1
12	IRON PIPING RVK 8-10	064-0081-S	1
12	IRON PIPING RVK 15-20	064-0071-S	1
13	IRON PIPING RVK 8-10	064-0041-S	1
13	IRON PIPING RVK 15-20	064-0031-S	1
16	AIR RADIATOR RVK 8-10	011-0584-S	1
16	AIR RADIATOR RVK 15-20	011-0585-S	1
17	COPPER WASHER 3/4"	015-015-S	1
18	DOUBLE SCREW 3/4"	187-060-S	1
19	PIPING 3/4" FD+F90 L=620	065-1860-S	1
20	DOUBLE SCREW 1" – 3/4"	187-065-S	1
21	COPPER WASHER 1"	015-018-S	2
22	SHORT-RADIUS ELBOW 1"M – 1"F	111-055-S	1
23	CONDENSATION SEPARATOR	217-200-S	1
24	REDUCTION ELEMENT 1"M – 3/4"F	190-059-S	1
25	IRON PIPING RVK 8-20	064-0021-S	1
26	IRON STRIP	149-236-S	1
27	FIXTURE BLADE OIL PIPE	120-1581-S	1
28	T.E. SCREW. 6X20	132-063-S	1
29	FLAT WASHER 6,6X12X1,5	015-027-S	2
30	M6 HEXAGONAL NUT	135-030-S	1
31	EXTENSION 3/4"M – 3/4"F L= 45	189-054-S	1
32	COCK ATTACHMENT SLEEVE 3/4"	063-108-S	1
33	ELBOW 3/4"	111-040-S	1
34	ELBOW JOINT 1/8"	148-100-S	1
35	POLYAMIDE PIPE DIAM. 8X6	089-070-S	1
36	THERMO-FAN SWITCH	154-037-S	1
37	CAP 14x1,5	106-126-S	1

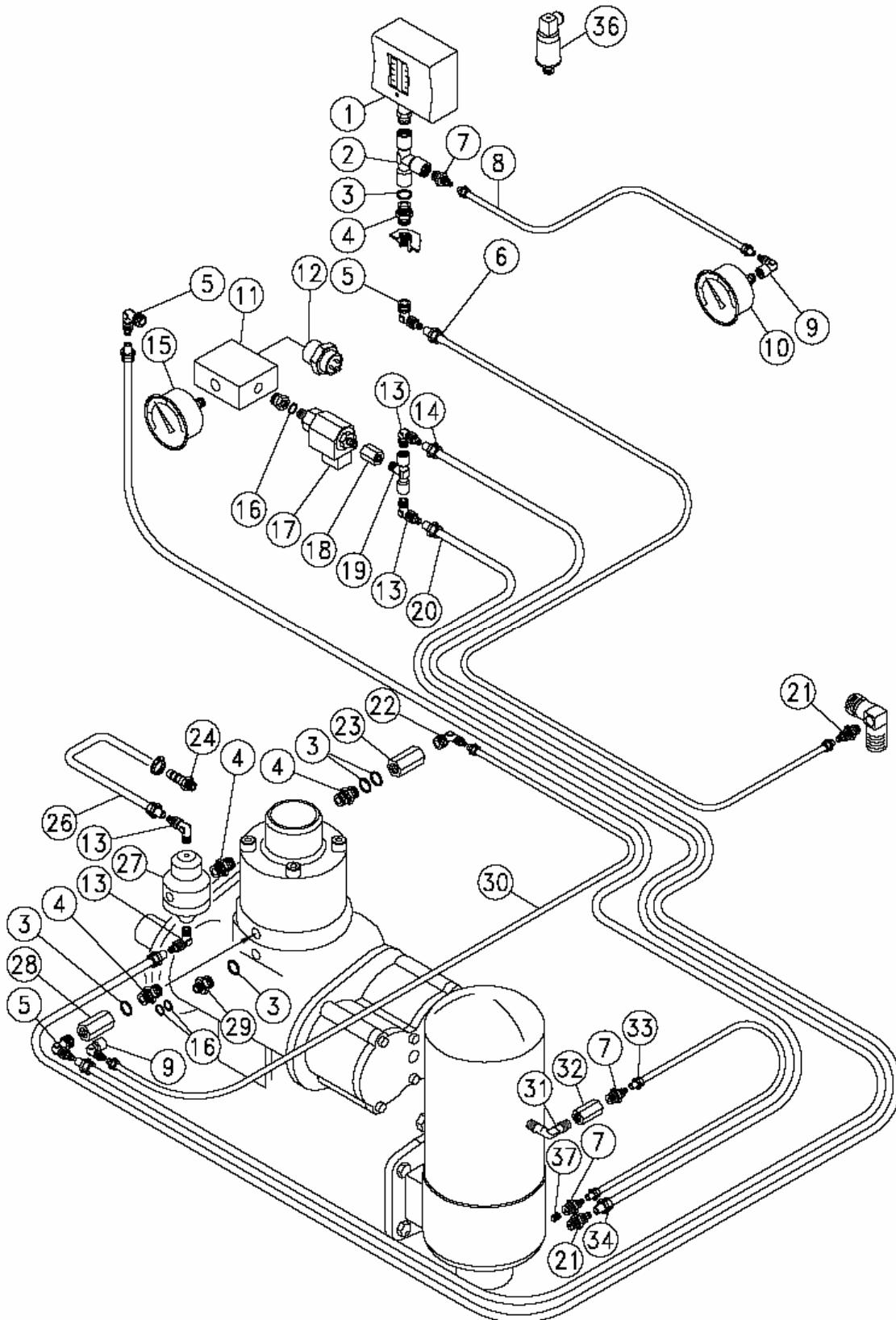

# **ROTAIR S.p.A.**

## **DETAILS LIST OF RVKi 8-10-15-20**

**TAB. 3**

<b>POSITION</b>	<b>DESCRIPTION</b>	<b>CODE</b>	<b>QUANTITY</b>
1	PRESSURE SWITCH	205-010-S	1
2	T-FITTING 1/4" F+F+F	148-142-S	1
3	COPPER WASHER 1/4"	015-007-S	4
4	DOUBLE SCREW 1/4"	187-005-S	1
5	ELBOW JOINT 1/4"	148-110-S	3
6	POLYAMIDE PIPE DIAM. 8X6	089-070-S	1
7	STRAIGHT COUPLING 1/8"	148-080-S	1
8	POLYAMIDE PIPE DIAM. 6X4	089-060-S	1
9	ELBOW JOINT 1/8"	148-100-S	1
10	PRESSURE MANOMETER	206-020-S	1
11	DEVICES ATTACHMENT BODY	053-295-S	1
12	OIL PRESSURE SWITCH	154-035-S	1
13	ELBOW JOINT 1/8"	148-100-S	4
14	POLYAMIDE PIPE DIAM. 8X6	089-070-S	1
15	PRESSURE MANOMETER	206-0205-S	1
16	COPPER WASHER 1/8"	015-005-S	1
17	SOLENOID VALVE 18VA 24V	160-070-S	1
18	SPACER 1/8"	009-014-S	1
19	T-FITTING F+M+F 1/8"	148-192-S	1
20	POLYAMIDE PIPE DIAM. 8X6	089-070-S	1
21	STRAIGHT COUPLING 1/8"	148-060-S	2
22	ELBOW JOINT 1/4"	148-090-S	1
23	NON-RETURN VALVE 1/4"	033-017-S	1
24	ELBOW JOINT 1/8"	148-100-S	4
26	POLYAMIDE PIPE DIAM. 8X6	089-070-S	1
27	VALVE ASSEMBLY 2 BAR	024-026-F	1
28	NON-RETURN VALVE 1/4"	033-017-S	1
29	DOUBLE SCREW 1/4" – 1/8"	187-002-S	1
30	POLYAMIDE PIPE DIAM. 6X4	089-060-S	1
31	ELBOW JOINT 1/8"	148-080-S	1
32	NON-RETURN VALVE 1/8"	033-001-S	1
33	POLYAMIDE PIPE DIAM. 6X4	089-060-S	1
34	POLYAMIDE PIPE DIAM. 8X6	089-070-S	1
36	PRESSURE TRANSDUCER (AIRMASTER version only)	205-030-S	1



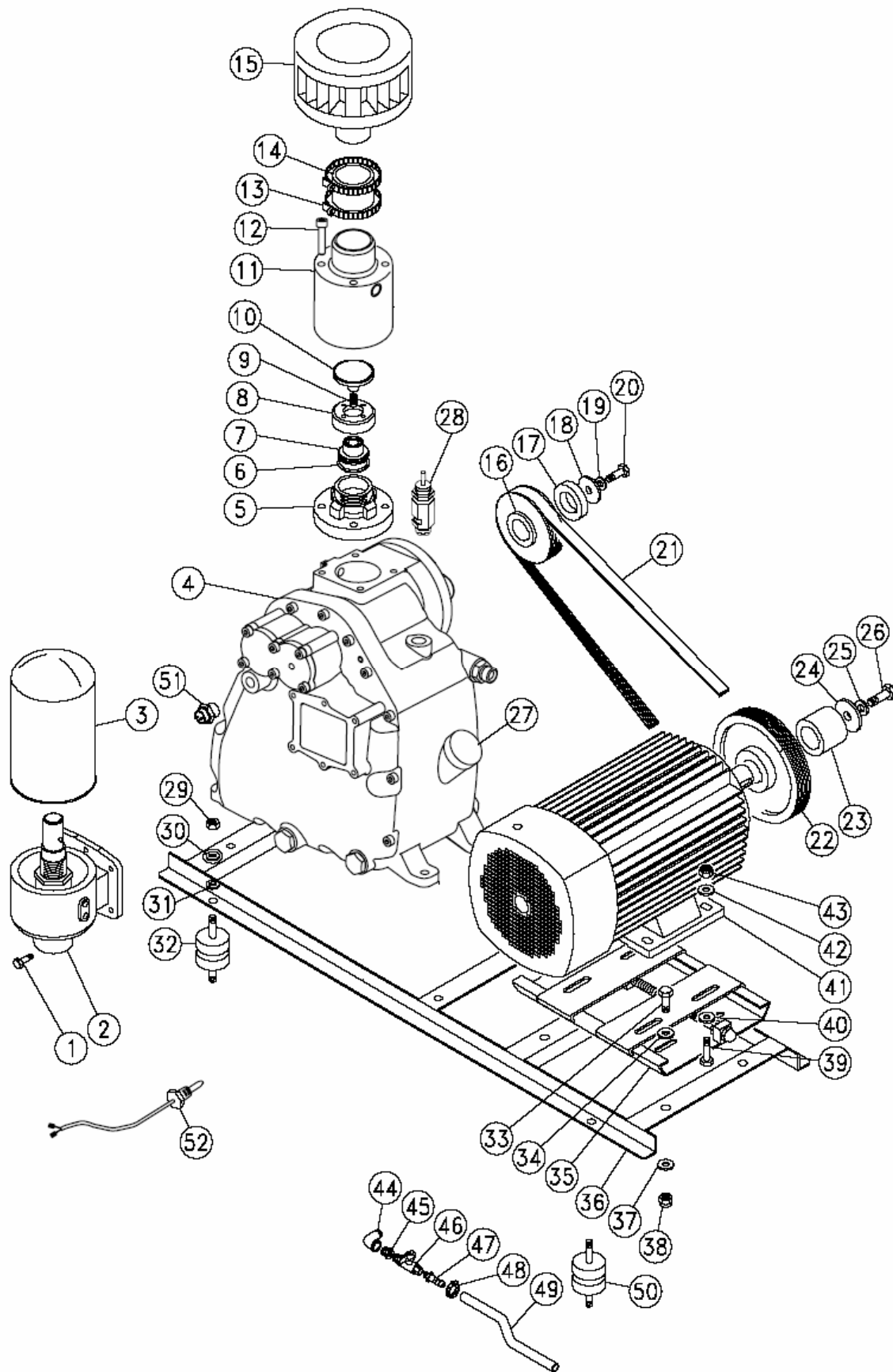

**DETAILS LIST OF RVKi 8-10-15-20****TAB. 4**

POSITION	DESCRIPTION	CODE	QUANTITY
1	T.E. SCREW 8X25	132-102-S	4
2	MINIMUM PRESSURE VALVE ASSEMBLY — SEPARATOR SUPPORT	024-202-F	1
3	OIL SEPARATOR FILTER	157-170-S	1
4	SCREW ASSEMBLY	024-086-F	1
5	REGULATOR BASE	034-0075-S	1
6	SEGMENT	199-050-S	1
7	REGULATOR PISTON	048-0265-S	1
8	ALUMINIUM RING	194-001-S	1
9	REGULATOR SPRING RVK 8-10	043-0114-S	1
9	REGULATOR SPRING RVK 15-20	043-0115-S	1
10	SUCTION VALVE RVK 8-10	033-0054-S	1
10	SUCTION VALVE RVK 15-20	033-0055-S	1
11	BODY OF REGULATOR	053-0764-S	1
12	TCEI SCREW 10X100	133-197-S	4
13	STRIP 50/70	149-150-S	2
14	PIPING 60X70 L=40	089-0765-S	1
15	AIR FILTER	162-578-S	1
16	RVK 8-15 COMPRESSOR PULLEY	050-415-S	1
16	RVK 20 COMPRESSOR PULLEY	050-4106-S	1
17	COMPRESSOR PULLEY SPACER	009-139-S	1
18	COMPRESSOR PULLEY WASHER	015-063-S	1
19	ELASTIC WASHER (GROWER) D.10	139-050-S	1
20	T.E. SCREW. 10x35	132-144-S	1
21	POLY-V RVK 8 BELT	156-0755-S	1
21	POLY-V RVK 10 BELT	156-076-S	1
21	POLY-V RVK 15/8 BELT	156-078-S	1
	POLY-V RVK 15/10 BELT	156-0765-S	
21	POLY-V RVK 20/8 BELT	156-003-S	1
21	POLY-V RVK 20/10 BELT	156-0083-S	1
22	RVK 8/8 MOTOR PULLEY	050-350-S	1
22	RVK 8/10 MOTOR PULLEY	050-416-S	1
22	RVK 10/8 MOTOR PULLEY	050-417-S	1
22	RVK 10/10 MOTOR PULLEY	050-355-S	1
22	RVK 15/8 MOTOR PULLEY	050-418-S	1
	RVK 15/10 MOTOR PULLEY	050-419-S	
22	RVK 20/8 MOTOR PULLEY	050-406-S	1

# **ROTAIR S.p.A.**

22	RVK 20/10 MOTOR PULLEY	050-407-S	1
23	MOTOR PULLEY SPACER	009-216-S	1
24	MOTOR PULLEY WASHER	015-052-S	1
25	ELASTIC WASHER (GROWER) D.12	139-060-S	1
26	T.E. SCREW. 12x45	132-193-S	1
27	OIL LEVEL ROD CAP	106-160-S	1
28	SAFETY VALVE 1/2"	033-051-S	1
29	M10 EXAGONAL NUT	135-050-S	2
30	FLAT WASHER 10x21x2	015-032-S	2
31	ELASTIC WASHER (GROWER) D.10	139-050-S	1
32	SILENT BLOCK M10	061-011-S	2
33	T.E. SCREW 10X25	132-142-S	4
34	FLAT WASHER 10x30x2	015-033-S	4
35	MOTOR-SLIDE SUPPORT	039-059-S	1
36	MOTOR-COMPRESSOR BASE RVK 8-20	034-0523-S	1
37	FLAT WASHER 10x30x2	015-033-S	4
38	SELF-LOCKING NUT M10	137-050-S	4
39	T.E. SCREW 10X40	132-145-S	4
40	FLAT WASHER 10x30x2	015-033-S	4
41	ELECTRIC MOTOR RVK 8	178-032-S	1
41	ELECTRIC MOTOR RVK 10	178-0502-S	1
41	ELECTRIC MOTOR RVK 15	178-0635-S	1
41	ELECTRIC MOTOR RVK 20	178-0903-S	1
42	FLAT WASHER 10x30x2	015-033-S	4
43	SELF-LOCKING NUT M10	137-050-S	4
44	SHORT-RADIUS ELBOW M1/2" F1/2"	111-030-S	1
45	REDUCTION ELEMENT 3/8"F - 1/4"M	190-020-S	1
46	BALL VALVE 1/4"	152-015-S	1
47	FITTING 1/4" M RESCA	148-198-S	1
48	PIPE-TIGHTENING STRIP 8/11	149-005-S	1
49	KRISTALL PIPE	089-100-S	1
50	SILENT BLOCK M8	061-0276-S	2
51	THERMO-CONTACT	103-012-S	1
52	TEMPERATURE TRANSDUCER (AIRMASTER version only)	103-050-S	1

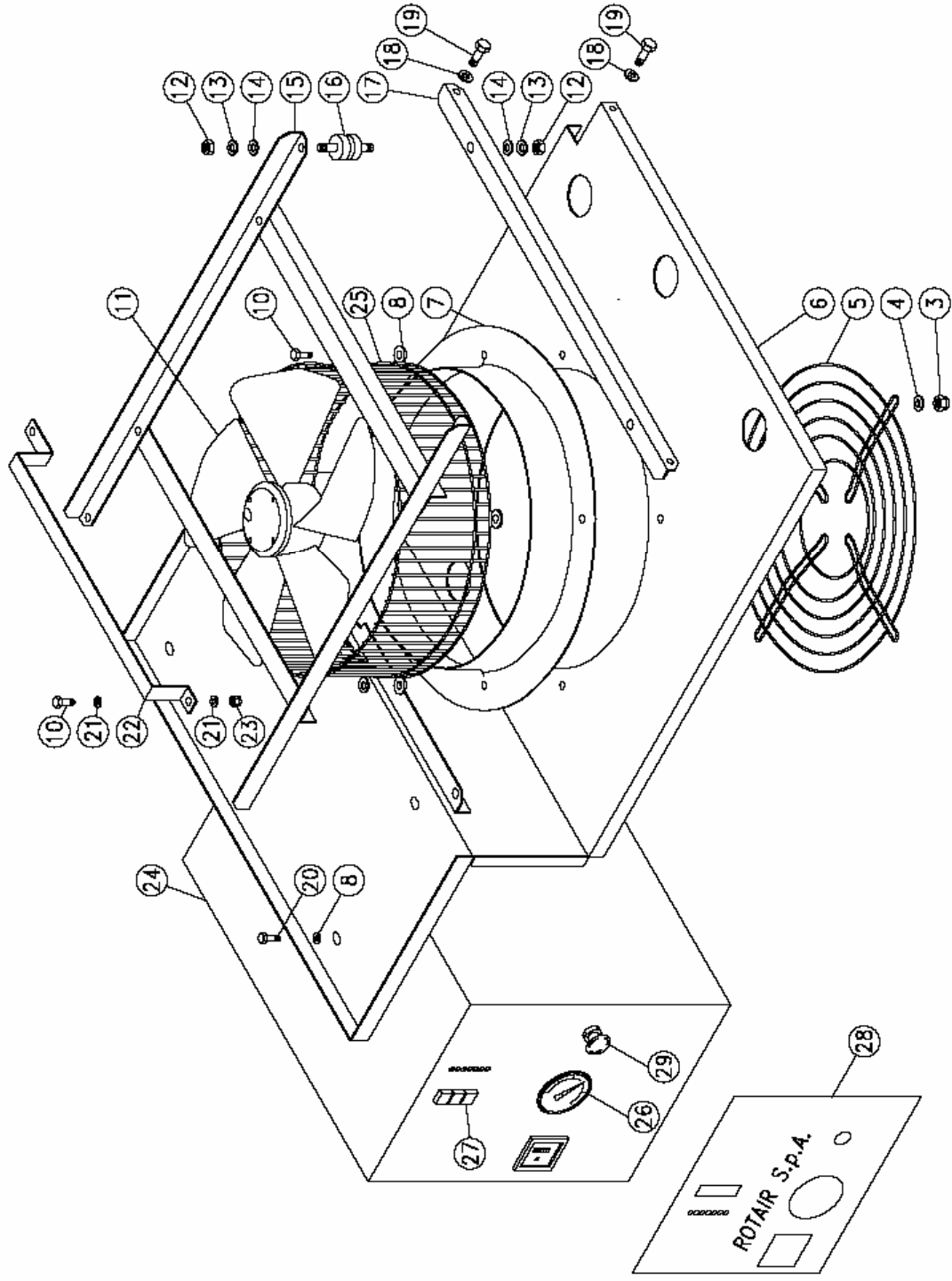

# **ROTAIR S.p.A.**

## **DETAILS LIST OF RVKi 8-10-15-20**

**TAB. 5**

<b>POSITION</b>	<b>DESCRIPTION</b>	<b>CODE</b>	<b>QUANTITY</b>
3	SELF-LOCKING NUT M6	137-030-S	4
4	FLAT WASHER 6,6X18X1,5	015-029-S	4
5	PROTECTIVE GRATING LOWER FAN	124-2188-S	1
6	INNER PANEL SUPPORT RADIATOR AND FAN	124-2042-S	1
7	CONVEYOR-NOZZLE ELECTRIC FAN	041-056-S	1
8	FLAT WASHER 6,6X18X1,5	015-029-S	8
10	T.E. SCREW. 6X20	132-063-S	8
11	ELECTRIC FAN	083-700-S	1
12	M8 HEXAGONAL NUT	135-040-S	8
13	ELASTIC WASHER (GROWER) D.8	139-040-S	8
14	FLAT WASHER 8,4X17X1,5	015-030-S	8
15	RADIATOR SUPPORT	049-081-S	1
16	SILENT BLOCK M8	061-026-S	4
17	BEARING RADIATOR BLADE	120-195-S	1
18	FLAT WASHER 6,6X12X1,5	015-027-S	4
19	T.E. SCREW. 6X16	132-062-S	4
20	T.E. SCREW 6X16	132-062-S	6
21	FLAT WASHER 6,6X12X1,5	015-027-S	8
22	RADIATOR FIXTURE BLADE RVK 8-10	120-1555-S	2
22	RADIATOR FIXTURE BLADE RVK 15-20	120-155-S	2
23	SELF-LOCKING NUT M6	137-030-S	4
24	ELECTRICAL APPLIANCES	*	
25	PROTECTIVE GRATING UPPER FAN	124-2183-S	1
26	THERMOMETER	167-030-S	1
27	ELECTRONIC CARD	269-410-S	1
27	ELECTRONIC CARD (AIRMASTER version)	269-400-S	1
28	ADHESIVE CONTROL PANEL	238-2173-S	1
29	EMERGENCY BUTTON	154-066-S	1

\* Please indicate the electro-compressor voltage and power on ordering.



Nuvair™ 2004 All Rights Reserved

Phone (805) 815-4044

Fax (805) 815-4196

2949 West 5th Street

Oxnard, CA 93030

USA

Email : [info@nuvair.com](mailto:info@nuvair.com)

Web : [www.nuvair.com](http://www.nuvair.com)

Rotair

Revision 0906